

BLUCAST 
making water accessible

**DUCTILE IRON VALVES
AND FITTINGS**
2024



COMPANY PRESENTATION

BLUCAST JOINT STOCK COMPANY was established in 2007 and is highly-focused on development of high quality, long lasting and low maintenance required products for water supply networks.

The dynamic development of the company and continuous expansion of the product range, the introduction of new technologies and management methods has resulted in increased competitiveness of our company in terms of both quality and price.

The goal of our company is to provide the global market with the complete range of high quality ductile iron products for water-supply sector that provides long-lasting cycle life in our sector and minimized maintenance costs while maintaining competitive price. This allows us to ensure that Consumers are protected from irrelevant costs. Fair price is our commitment to them.

We know, for the same financial amount it is possible to complete more renovations and reach more consumers with clean water. Furthermore, we strive to complete more water network projects for the same funds to ensure even more people could experience the benefits of clear water in their house.



7

Years Warranty



3000

Unique Products



1000

Tons On Stock



27







Countries



2800

Max Diameters

CONTENTS

VALVES		2
DUCTILE IRON FITTINGS		18
FLANGE ADAPTORS AND COUPLINGS		26
TAPPING SADDLES		31
OTHER PRODUCTS		35
CERTIFICATES		38



GATE VALVE PN16 (F4) series 115



APPLICATION

Flanged gate valve for drinking water and neutral liquids up to 70°C

DESIGN FEATURES

Non rising stainless steel stem	100% watertight
Full bore	No zones of retention
Low closing torque	Replaceable wedge nut
Clockwise closing	Dust protection flanges for sizes DN40-DN250
Maintenance free	Edge protection gasket to avoid damages during transport, storage and assembly for sizes DN40-DN300
Guided wedge to ensure correct sealing	

TECHNICAL CHARACTERISTICS

Design in accordance to EN1074 and EN1171
 Face to face dimensions according to EN 558-1 series 14 and DIN3202 (F4)
 Flange end connections according to EN1092-2: PN10&PN16
 Maximum working pressure: PN16 / 16 bar
 Working temperature: 0°C - +70°C
 Fully vulcanized wedge in EPDM according to EN681
 Stainless steel bolts
 Color RAL5015
 Powder epoxy coating at least 250 µm thickness

OPERATING



DN	Flange drilling	L	H	H1	D	D1	D2	b	n-Ød	SQ	KG	BLUCAST ref. no.
40	PN10/16	140	220	295	150	110	84	16	4-Ø19	14	9	115040
50	PN10/16	150	230	312,5	165	125	99	16	4-Ø19	14	10,6	115050
60/65	PN10/16	170	265	357,5	185	145	118	16	4-Ø19	17	11	115065
80	PN10/16	180	290	390	200	160	132	16	8-Ø19	17	12,6	115080
80	PN10/16	180	290	390	200	160	132	16	4-Ø19	17	12,6	115H080
100	PN10/16	190	335	445	220	180	156	16	8-Ø19	19	18	115100
125	PN10/16	200	380	505	250	210	184	16	8-Ø19	19	26,9	115125
150	PN10/16	210	415	557,5	285	240	211	16	8-Ø23	19	30,2	115150
200	PN10	230	510	680	340	295	266	17	8-Ø23	24	53	115200
200	PN16	230	510	680	340	295	266	17	12-Ø23	24	53	115P200
250	PN10	250	600	800	400	350	319	19	12-Ø23	27	73,5	115250
250	PN16	250	600	800	400	355	319	19	12-Ø28	27	73,5	115P250
300	PN10	270	690	917,5	455	400	370	20,5	12-Ø23	27	107,4	115300
300	PN16	270	690	917,5	455	410	370	20,5	12-Ø28	27	107,4	115P300
350	PN10	290	790	1042,5	505	460	429	22,5	16-Ø23	27	158,4	115350
350	PN10/16	290	790	1050	520	470	429	22,5	16-Ø28	27	158,4	115U350
400	PN10	310	855	1137,5	565	515	480	24	16-Ø28	27	201	115400
400	PN10/16	310	855	1145	580	525	480	24	16-Ø31	27	201	115U400
500	PN10	350	1072	1407	670	620	582	31,5	20-Ø28	32	344	115500
500	PN10/16	350	1072	1429,5	715	650	609	31,5	20-Ø34	32	344	115U500
600	PN10	390	1228	1618	780	725	682	36	20-Ø31	32	543	115600
600	PN10/16	390	1228	1648	840	770	720	36	20-Ø37	32	543	115U600

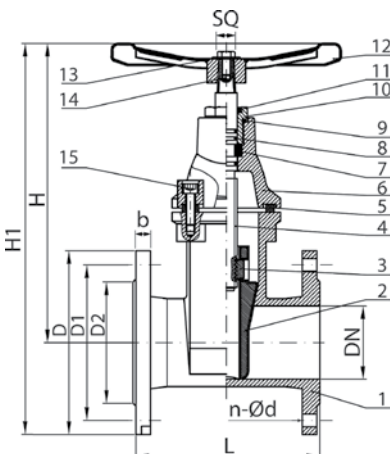

No.	Item	Material
1	Body	EN-GJS-500-7
2	Wedge	EN-GJS-500-7, EPDM
3	Stem nut	Brass
4	Stem	AISI420
5	Sealing gasket	EPDM
6	Bonnet	EN-GJS-500-7
7	Locating ring	Brass
8	Sealing ring	EPDM
9	Sealing ring	EPDM
10	Sealing nut	Brass
11	Sealing ring	EPDM
12	Handwheel	EN-GJS-500-7
13	Washer	AISI304
14	Bolt	AISI304
15	Bolt	AISI304

All illustrations, technical data, dimensions (in mm) and weights (all weights specified in kg) are non-binding and are subject to change



GATE VALVE PN16 (F5) series 115



APPLICATION

Flanged gate valve for drinking water and neutral liquids up to 70°C

DESIGN FEATURES

Non rising stainless steel stem	100% watertight
Full bore	No zones of retention
Low closing torque	Replaceable wedge nut
Clockwise closing (anti-clockwise closing option available)	Dust protection flanges for sizes DN40-DN250
Maintenance free	Edge protection gasket to avoid damages during transport, storage and assembly for sizes DN40-DN300
Guided wedge to ensure correct sealing	

TECHNICAL CHARACTERISTICS

Design in accordance to EN1074 and EN1171
 Face to face dimensions according to EN 558-1 series 15 and DIN3202 (F5)
 Flange end connections according to EN1092-2: PN10&PN16
 Maximum working pressure: PN16 / 16 bar
 Working temperature: 0°C - +70°C
 Fully vulcanized wedge in EPDM according to EN681
 Stainless steel bolts
 Color RAL5015
 Powder epoxy coating at least 250 µm thickness

OPERATING



DN	Flange drilling	L	H	H1	D	D1	D2	b	n-Ød	SQ	KG	BLUCAST ref. no.
40	PN10/16	240	220	295	150	110	84	16	4-Ø19	14	10	115F5040
50	PN10/16	250	230	312,5	165	125	99	16	4-Ø19	14	11,8	115F5050
60/65	PN10/16	270	265	357,5	185	145	118	16	4-Ø19	17	12,2	115F5065
80	PN10/16	280	290	390	200	160	132	16	8-Ø19	17	14,4	115F5080
100	PN10/16	300	335	445	220	180	156	16	8-Ø19	19	20,2	115F5100
125	PN10/16	325	380	505	250	210	184	16	8-Ø19	19	32,7	115F5125
150	PN10/16	350	415	557,5	285	240	211	16	8-Ø23	19	34,8	115F5150
200	PN10/16	400	510	680	340	295	266	17	8-Ø23 / 12-Ø23	24	64	115F5200
250	PN10/16	450	600	800	400	355	319	19	12-Ø23 / 12-Ø28	27	87	115F5250
300	PN10/16	500	690	917,5	455	410	377	20,5	12-Ø23 / 12-Ø28	27	146	115F5300
400	PN10	600	855	1137,5	565	515	480	24	16-Ø28	27	251	115F5400
400	PN16	600	855	1145	580	525	480	24	16-Ø31	27	251	115F5P400
500	PN10	700	1072	1407	670	620	582	31,5	20-Ø28	32	402	115F5500
500	PN16	700	1072	1429,5	715	650	609	31,5	20-Ø34	32	402	115F5P500
600	PN10	800	1228	1618	780	725	682	36	20-Ø31	32	642	115F5600
600	PN16	800	1228	1648	840	770	720	36	20-Ø37	32	642	115F5P600

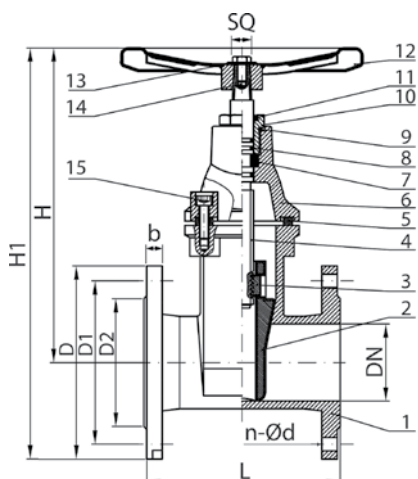

No.	Item	Material
1	Body	EN-GJS-500-7
2	Wedge	EN-GJS-500-7, EPDM
3	Stem nut	Brass
4	Stem	AISI420
5	Sealing gasket	EPDM
6	Bonnet	EN-GJS-500-7
7	Locating ring	Brass
8	Sealing ring	EPDM
9	Sealing ring	EPDM
10	Sealing nut	Brass
11	Sealing ring	EPDM
12	Handwheel	EN-GJS-500-7
13	Washer	AISI304
14	Bolt	AISI304
15	Bolt	AISI304



All illustrations, technical data, dimensions (in mm) and weights (all weights specified in kg) are non-binding and are subject to change



GATE VALVE

for electric actuator PN16 (F4) series 115



APPLICATION

Flanged gate valve for drinking water and neutral liquids up to 70°C

DESIGN FEATURES

Non rising stainless steel stem
Full bore
Low closing torque
Clockwise closing
Maintenance free

Guided wedge to ensure correct sealing
100% watertight
No zones of retention
ISO5210 top flange for mounting an actuator

TECHNICAL CHARACTERISTICS

Design in accordance to EN1074 and EN1171
Face to face dimensions according to EN 558-1 series 14 and DIN3202 (F4)
Flange end connections according to EN1092-2: PN10&PN16
Top flange connection according to ISO5210
Maximum working pressure: PN16 / 16 bar
Working temperature: 0°C - +70°C
Fully vulcanized wedge in EPDM according to EN681
Stainless steel bolts
Color RAL5015
Powder epoxy coating at least 250 µm thickness

OPERATING



DN	Flange drilling	L	H	H1	D	D1	D2	b	n-Ød	Top flange size ISO5210	SQ	Torque (Nm)	KG	BLUCAST ref. no.
40	PN10/16	140	220	295	150	110	84	16	4-Ø19	F10	20	30	9,9	115E050
50	PN10/16	150	230	312,5	165	125	99	16	4-Ø19	F10	20	40	11,66	115E050
65	PN10/16	170	265	357,5	185	145	118	16	4-Ø19	F10	20	60	12,1	115E065
80	PN10/16	180	290	390	200	160	132	16	8-Ø19	F10	20	60	13,86	115E080
100	PN10/16	190	335	445	220	180	156	16	8-Ø19	F10	20	80	19,8	115E100
125	PN10/16	200	380	505	250	210	184	16	8-Ø19	F10	20	100	29,59	115E125
150	PN10/16	210	415	557,5	285	240	211	16	8-Ø23	F10	20	125	33,22	115E150
200	PN10	230	510	680	340	295	266	17	8-Ø23	F14	30	150	58,3	115E200
200	PN16	230	510	680	340	295	266	17	12-Ø23	F14	30	150	58,3	115EU200
250	PN10	250	600	800	400	350	319	19	12-Ø23	F14	30	200	81	115E250
250	PN16	250	600	800	400	355	319	19	12-Ø28	F14	30	200	81	115EU250
300	PN10	270	690	917,5	455	400	370	20,5	12-Ø23	F14	30	250	118	115E300
300	PN16	270	690	917,5	455	410	370	20,5	12-Ø28	F14	30	250	118	115EU300
350	PN10	290	790	1042,5	505	460	429	22,5	16-Ø23	F14	30	300	174	115E350
350	PN16	290	790	1050	520	470	429	22,5	16-Ø28	F14	30	300	174	115EU350
400	PN10	310	855	1137,5	565	515	480	24	16-Ø28	F14	30	350	221	115E400
400	PN16	310	855	1145	580	525	480	24	16-Ø31	F14	30	350	221	115EU400
500	PN10	350	1072	1407	670	620	582	31,5	20-Ø28	F16	35	500	379	115E500
500	PN16	350	1072	1429,5	715	650	609	31,5	20-Ø34	F16	35	500	379	115EU500
600	PN10	390	1228	1618	780	725	682	36	20-Ø31	F16	35	650	597	115E600
600	PN16	390	1228	1648	840	770	720	36	20-Ø37	F16	35	650	597	115EU600

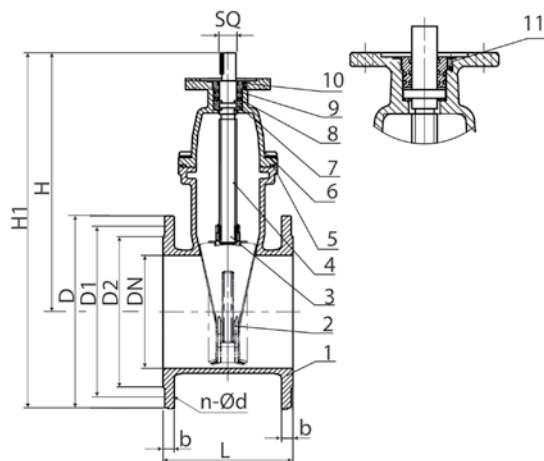

No.	Item	Material
1	Body	EN-GJS-500-7
2	Wedge	EN-GJS-500-7, EPDM
3	Stem Nut	Brass
4	Stem	AISI420
5	Sealing Gasket	EPDM
6	Bonnet	EN-GJS-500-7
7	Locating ring	Brass
8	O ring	EPDM
9	O ring	EPDM
10	Seal	Brass
11	Bolt	AISI304

GATE VALVE PN16 (F4) series 117



VALVES



APPLICATION

Flanged gate valve for drinking water and neutral liquids up to 70°C

DESIGN FEATURES

Non rising stainless steel stem	Guided wedge to ensure correct sealing
Full bore	100% watertight
Low closing torque	No zones of retention
Clockwise closing	Replaceable wedge nut

TECHNICAL CHARACTERISTICS

Design in accordance to EN1074 and EN1171
 Face to face dimensions according to EN 558-1 and DIN3202 (F4)
 Flange end connections according to EN1092-2: PN10&PN16
 Maximum working pressure: PN16 / 16 bar
 Working temperature: 0°C - +70°C
 Fully vulcanized wedge in EPDM according to EN681
 Stainless steel bolts
 Color RAL5015
 Powder epoxy coating at least 250 µm thickness

OPERATING



DN	Flange drilling	L	H	D	D1	D2	b	n-Ød	SQ	KG	BLUCAST ref. no.
50	PN10/16	150	198	165	125	99	16	4x19	14	10.6	117050
65	PN10/16	170	252	185	145	118	16	4x19	14	11	117065
80	PN10/16	180	255	200	160	132	16	8x19	17	12.6	117080
100	PN10/16	190	301	220	180	156	16	8x19	17	18	117100
125	PN10/16	200	336	250	210	184	16	8x19	19	26.9	117125
150	PN10/16	210	364	285	240	211	16	8x23	19	30.2	117150
200	PN10	230	473	340	295	266	17	8x23	24	53	117200
250	PN10	250	550	400	350	319	19	12x23	27	73.5	117250
300	PN10	270	642	455	400	370	20.5	12x23	27	107.4	117300
350	PN10	290	777	505	460	429	20.5	16x23	27	155	117350
400	PN10	310	852	565	515	480	20.5	16x28	27	200.8	117400
450	PN10	330	945	615	565	530	21.5	20x28	27	295	117450
500	PN10	350	1030	670	620	582	22.5	20x28	32	340	117500
600	PN10	390	1165	780	725	682	25	20x32	32	535	117600

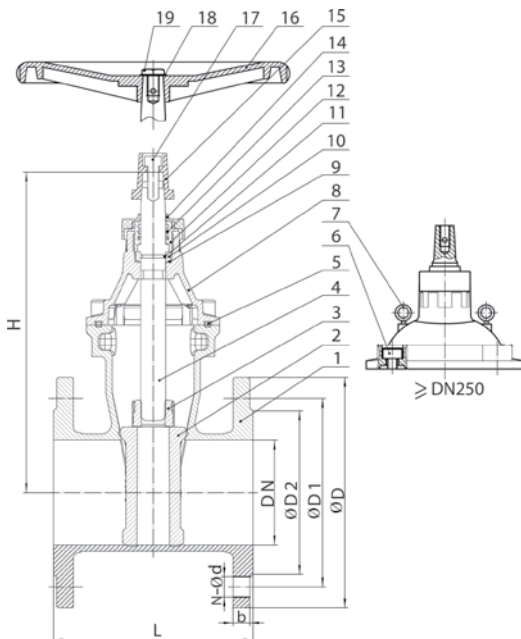

No.	Item	Material
1	Body	EN-GJS-500-7
2	Wedge	EN-GJS-500-7, EPDM
3	Wedge nut	Brass
4	Stem	AISI 420
5	Sealing gasket	EPDM
6	Bolts	AISI 304
7	Lifting bolt	AISI 304
8	Bonnet	EN-GJS-500-7
9	Sealing ring	EPDM
10	Sealing ring	EPDM
11	Sealing ring	EPDM
12	Stem nut	Brass
13	Sealing ring	EPDM
14	Dust seal	EPDM
15	Stem cap	EN-GJS-500-7
16	Handwheel	EN-GJS-500-7
17	Bolts	AISI 304
18	Washer	AISI 304
19	Bolts	AISI 304

All illustrations, technical data, dimensions (in mm) and weights (all weights specified in kg) are non-binding and are subject to change



THREADED GATE VALVE PN16 series 015



VALVES



APPLICATION

Threaded gate valve for drinking water and neutral liquids up to 80°C

DESIGN FEATURES

Non rising stainless steel stem
 Thread connection according to PN-EN ISO 228-1
 Straight passage without slots
 Low closing torque

100% watertight, class A
 No zones of retention
 Clockwise closing

TECHNICAL CHARACTERISTICS

Requirements and tests: according to PN-EN 1074-1.2
 Maximum working pressure: PN16 / 16 bar
 Working temperature: 0°C - +80°C
 Powder epoxy coating at least 250 µm thickness, UV resistant, Color RAL5015
 Sealing torque: DN20-DN32-15Nm, DN40-DN50-30Nm
 Spindle/ shaft seal: O-ring
 Maximum water speed: 4 m/s
 Version with both internal threads - code "VV".
 Version with internal/external threads - code "VI".

OPERATING



DN	Threads G	H	L	P	SQ	Kg	BLUCAST ref. no.
20	3/4" int/int	145	95	27	12	1.2	015VV020
25	1" int/int	145	105	30	12	1.5	015VV025
32	1 1/4" int/int	150	120	32	12	2	015VV032
40	1 1/2" int/int	197	130	37	14	3	015VV040
50	2" int/int	202	150	45	14	4	015VV050
25	1" int/ext	145	130	30	12	1.5	015VI025
32	1 1/4" int/ext	150	145	32	12	2	015VI032
40	1 1/2" int/ext	197	155	37	14	3	015VI040
50	2" int/ext	202	175	45	14	4	015VI050

No.	Item	Material
1	Body	EN GJS-500-7
2	Wedge	DN20-DN32 EN Brass/EPDM, DN40-DN50 - EN GJS-500-7/EPDM
3	Bonnet gasket	EPDM
4	Stem	A2 stainless steel
5	Bonnet	EN GJS-500-7
6	Thrust washer	Brass
7	Thrust	Brass
8	Thrust nut	Brass
9	O ring	EPDM
10	O ring	EPDM
11	O ring	EPDM
12	O ring	EPDM
13	Bolts	A2 stainless steel
14	Stem nut	Brass

DN20/DN25/DN32

DN40/DN50

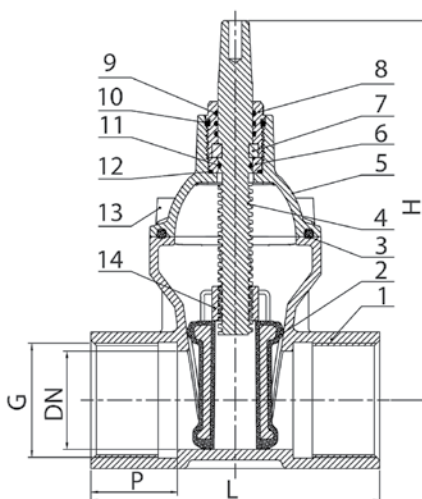
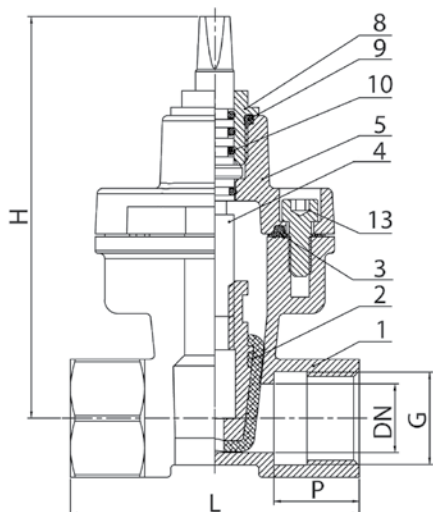

All illustrations, technical data, dimensions (in mm) and weights (all weights specified in kg) are non-binding and are subject to change



DOUBLE ECCENTRIC BUTTERFLY VALVE series DEBV

APPLICATION

Double eccentric butterfly valve used for regulation and sectioning of the flow for drinking water and neutral liquids up to 70°C

DESIGN FEATURES

- 100% watertight
- Stainless steel stem
- Mechanical position indicator
- Mechanical gearbox included
- Clockwise closing
- DN400 and above – handwheel and ISO5211 top flange for mounting electric actuator

TECHNICAL CHARACTERISTICS

- Design in accordance to EN593
- Face to face dimensions according to EN558: Series 14 (F4)
- Flange end connections according to EN1092-2: PN10 (PN16 & PN25 options are available)
- Maximum working pressure: PN10 / 10 bar (PN16 & PN25 options available)
- Working temperature: 0°C - +70°C
- Gearbox operated
- EPDM sealing
- Stainless steel bolts
- Color RAL5015
- Powder epoxy coating 250 µm thickness
- PN10 - bi-directional seal

OPERATING



VALVES

DN	L	H1	H2	ISO flange size on gearbox	Weight	BLUCAST ref. no.
100	190	122	178	Handwheel only	27	DEBV100
150	210	162	238	Handwheel only	38	DEBV150
200	230	177	250	Handwheel only	53	DEBV200
250	250	210	295	Handwheel only	73	DEBV250
300	270	258	306	Handwheel only	112	DEBV300
350	290	283	335	Handwheel only	131	DEBV350
400	310	325	538	F10	169	DEBV400
450	330	340	550	F10	200	DEBV450
500	350	375	590	F10	253	DEBV500
600	390	443	683	F10	384	DEBV600
700	430	485	732	F14	488	DEBV700
800	470	560	788	F14	631	DEBV800
900	510	601	867	F14	903	DEBV900
1000	550	680	907	F14	1160	DEBV1000
1200	630	791	1030	F14	1651	DEBV1200
1400	710	1031	1285	F14	3113	DEBV1400
1600	790	1170	1312	F16	3451	DEBV1600
1800	870	1270	1491	F16	4820	DEBV1800
2000	950	1360	1610	F16	5185	DEBV2000
2200	1030	1450	1725	F16	5550	DEBV2200

No.	Item	Material
1	Bolts	A2
2	Cover	EN-GJS-400-15
3	O-ring	EPDM
4	Bush	Steel
5	Body	EN-GJS-400-15
6	Body seal ring	Welded AISI304
7	Disc seal ring	EPDM
8	Bolts	A2
9	Disc	EN-GJS-400-15
10	Lower stem	AISI 420
11	Upper stem	AISI 420
12	Pin	AISI 420
13	Retainer ring	Q235
14	O-Ring	EPDM
15	Suffing pad	EN-GJS-400-15
16	Bolts	A2
17	Gearbox	EN-GJS-400-15

DN100-DN350

DN400-DN2000

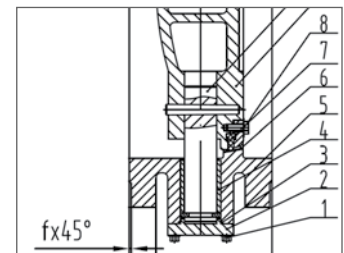
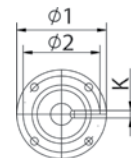
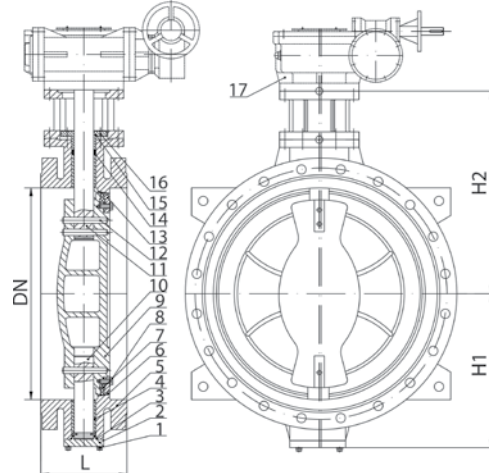
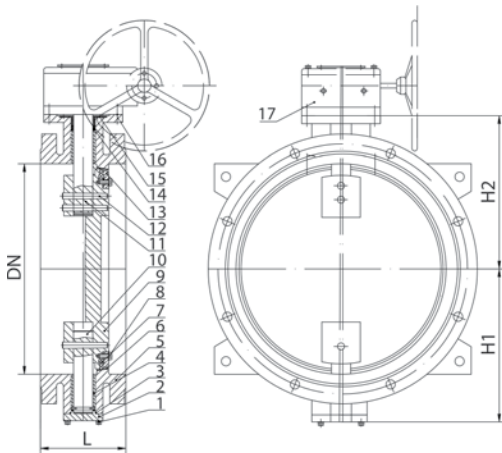

All illustrations, technical data, dimensions (in mm) and weights (all weights specified in kg) are non-binding and are subject to change



SWING CHECK VALVE series ASV



APPLICATION

Swing check valve used for stopping of backflow of drinking water and neutral liquids up to 80°C

DESIGN FEATURES

Simple and compact design
Can be installed in vertical and horizontal positions
Maintenance free

TECHNICAL CHARACTERISTICS

Face to face dimensions according to EN558 series 48 / DIN3202 (F6)
Flange end connections according to EN1092: PN10&PN16
Maximum working pressure: PN16
Working temperature: 0-80°C
Color RAL5015
Powder epoxy coating 250 µm thickness
Hydraulic test according to EN12266

DN	Flange drilling	L	D	D1	D2	b	n-Ød	KG	BLUCAST ref. no.
50	PN10/16	200	165	125	100	19	4-Ø19	8.5	ASV050
65	PN10/16	240	185	145	120	19	4-Ø19	10.2	ASV065
80	PN10/16	260	200	160	135	19	8-Ø19	14.4	ASV080
100	PN10/16	300	220	180	156	19	8-Ø19	19.1	ASV100
125	PN10/16	350	250	210	186	19	8-Ø19	26.3	ASV125
150	PN10/16	400	285	240	212	19	8-Ø23	33.5	ASV150
200	PN10	500	340	295	268	20	8-Ø23	68.5	ASV200
250	PN10	600	405	350	318	22	12-Ø23	125	ASV250
300	PN10	700	460	400	370	24.5	12-Ø23	160	ASV300

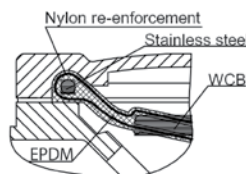
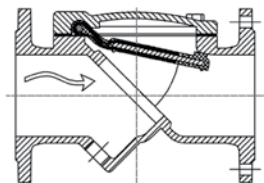
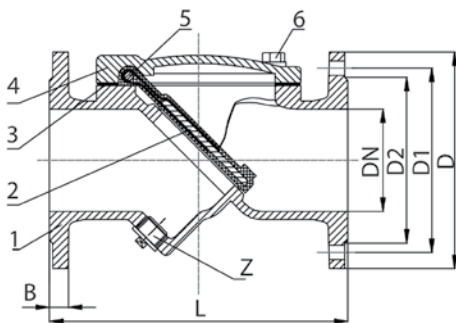

No.	Item	Material
1	Body	EN GJS-500-7
2	Disc	WCB+EPDM
3	Gasket	EPDM
4	Bonnet	EN GJS-500-7
5	Pin	AISI304
6	Bolts	AISI304
7	Plug	AISI304

BALL CHECK VALVE series ARV



APPLICATION

Ball check valves for drinking water and neutral liquids up to 70°C
NBR version for sewage

DESIGN FEATURES

Self cleaning construction
Full bore
Easy disassembly of the top cap to remove the ball
Simple and compact design
Can be installed in vertical and horizontal positions

TECHNICAL CHARACTERISTICS

Maximum working pressure: PN10 / PN16
Working temperature: 0°C - +70°C
Fully vulcanized ball in EPDM (NBR option available)
Color RAL5015
Powder epoxy coating 250 µm thickness
Bonnet gasket in EPDM

Flanged version:

Design in accordance to EN12050
Face to face dimensions according to:
EN558 series 48 / DIN 3202 (F6)
Flange end connections according to
EN1092-2: PN10&PN16

Threaded version:

Thread connections according to EN 10226-1



VALVES

DN	Flange drilling	L	D	D1	D2	b	n-Ød	KG	BLUCAST ref. no.
32	1 1/4" thread	140	-	-	-	18	-	2,5	ARVV032
40	1 1/2" thread	145	-	-	-	18	-	2,6	ARVV040
50	2" thread	170	-	-	-	20	-	3,8	ARVV050
50	PN10/16	200	165	125	102	19	4-Ø19	8,5	ARV050
65	PN10/16	240	185	145	122	19	4-Ø19	9,5	ARV065
80	PN10/16	260	200	160	138	19	8-Ø19	12	ARV080
100	PN10/16	300	220	180	158	19	8-Ø19	16	ARV100
125	PN10/16	350	250	210	188	19	8-Ø19	22	ARV125
150	PN10/16	400	285	240	212	19	8-Ø23	31	ARV150
200	PN10	500	340	295	268	20	8-Ø23	68	ARV200
250	PN10	600	405	350	319	22	12-Ø23	100	ARV250
300	PN10	700	460	400	370	24,5	12-Ø23	132	ARV300
400	PN10	900	580	515	480	28	16-Ø28	275	ARV400
500	PN10	1100	715	620	582	31	20-Ø28	550	ARV500
200	PN16	500	340	295	266	20	12-Ø23	68	ARVP200
250	PN16	600	400	355	319	22	12-Ø28	100	ARVP250
300	PN16	700	455	410	370	24,5	12-Ø28	132	ARVP300

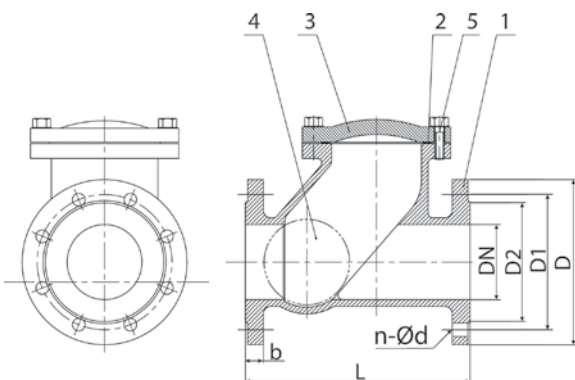

No.	Item	Material
1	Body	EN-GJS-400-15
2	Gasket	EPDM
3	Cover	EN-GJS-400-15
4	Ball	Q235 Steel + EPDM
5	Bolt	Zinc plated 4.8 steel or Stainless steel AISI304

All illustrations, technical data, dimensions (in mm) and weights (all weights specified in kg) are non-binding and are subject to change

BUTTERFLY VALVE series VB



VALVES



APPLICATION

Wafer butterfly valve for drinking water and neutral liquids up to 70°C

DESIGN FEATURES

Wafer type for mounting between two flanges

Stainless steel stem

Mechanical position indicator

ISO5211 top flange mounting actuator

Clockwise closing

100% watertight

TECHNICAL CHARACTERISTICS

Design in accordance to EN593

Face to face dimensions according to EN558: Series 20

Flange end connections according to EN1092-2: PN10&PN16

Top flange connection according to ISO5211

Maximum working pressure: PN16 / 16 bar

Working temperature: 0°C - +70°C

DN50-DN250 - lever operated, DN300 and above - with gearbox

EPDM seat

Stainless steel bolts

Color RAL5015

Powder epoxy coating 250 µm thickness

OPERATING



DN	Flange drilling	L	H	H1	D1	n-Ød	Top flange size ISO5211	KG	BLUCAST ref. no.
50	PN10/16	42	161	241	125	4-Ø18	F05	3,7	VB050
65	PN10/16	44.5	175	264	145	4-Ø18	F05	4,4	VB065
80	PN10/16	45	181	276	160	4-Ø18	F05	4,9	VB080
100	PN10/16	51	200	314	180	8-Ø18	F07	6,5	VB100
125	PN10/16	54.5	213	340	210	8-Ø18	F07	7,8	VB125
150	PN10/16	54.8	226	365	240	8-Ø23	F07	9,2	VB150
200	PN10	59.6	260	440	295	8-Ø23	F10	14,7	VB200
250	PN10	67	292	500	350	12-Ø23	F10	21,2	VB250
300	PN10	75.9	337	584	400	12-Ø23	F10	35,2	VB300
350	PN10	79	267	368	460	16-Ø23	F12	58,8	VB350
400	PN10	90	298	400	515	16-Ø28	F14	101,2	VB400
500	PN10	132	349	480	620	20-Ø28	F14	160,1	VB500
600	PN10	156	410	562	725	20-Ø31	F16	257,5	VB600
50	PN10/16	161	161	241	125	4-Ø18	F05	3,7	VBSS050
65	PN10/16	175	175	264	145	4-Ø18	F05	4,4	VBSS065
80	PN10/16	181	181	276	160	4-Ø18	F05	4,9	VBSS080
100	PN10/16	200	200	314	180	8-Ø18	F07	6,5	VBSS100
150	PN10/16	226	226	365	240	8-Ø23	F07	9,2	VBSS150
200	PN10	260	260	440	295	8-Ø23	F10	14,7	VBSS200

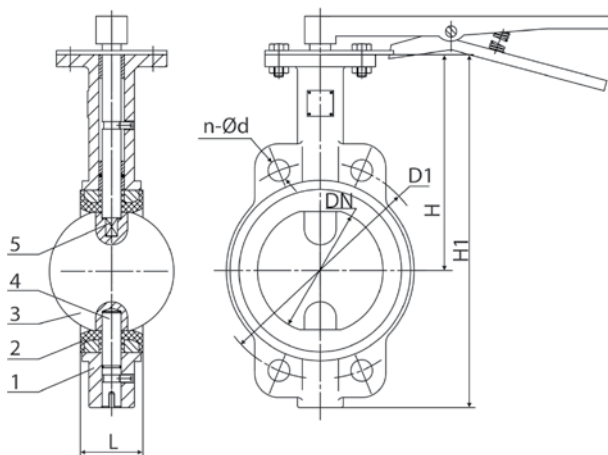

No.	Item	Material
1	Body	EN-GJS-500-7
2	Seat	EPDM
3	Disc (series VB) Disc (series VBSS)	EN-GJS-500-7, Nickel plated Stainless steel CF8 (AISI304)
4	Upper stem	Stainless steel AISI420
5	Lower stem	Stainless steel AISI420

All illustrations, technical data, dimensions (in mm) and weights (all weights specified in kg) are non-binding and are subject to change



KNIFE GATE VALVE series PS



APPLICATION

Resilient seat knife gate valve for drinking water and neutral liquids up to 70°C

DESIGN FEATURES

Stainless steel stem
100% watertight
Single or Double directional tightness
Clockwise closing
Non-rising stem

TECHNICAL CHARACTERISTICS

Design in accordance to EN1074
Flange end connections according to EN1092-2: PN10&PN16
Maximum working pressure: DN50-DN250 - PN10/10 bar, DN300-DN400 - PN6/6 bar, DN500-DN600 - PN4/4 bar
Working temperature: 0°C - +70°C
EPDM seat
Stainless steel bolts
Color RAL5015
Handwheel operated (DN50-DN400), from DN500 - with gearbox
Powder epoxy coating 250 µm thickness

OPERATING



VALVES

DN	Flange drilling	L	H	H1	D2	D1	D	n-Ød	n-Th	KG	BLUCAST ref. no.
50	PN10/16	48	290	339,5	99	125	165	4-Ø18	4-M16	7	PS050
65	PN10/16	48	320	379	118	145	185	4-Ø18	4-M16	8	PS065
80	PN10/16	51	350	416	132	160	200	4-Ø18	8-M16	10	PS080
100	PN10/16	51	385	463	156	180	220	8-Ø18	8-M16	13	PS100
125	PN10/16	57	430	522	184	210	250	8-Ø18	8-M16	18	PS125
150	PN10/16	57	485	591	212	240	285	8-Ø23	8-M20	23	PS150
200	PN10	60	565	698	266	295	340	8-Ø23	8-M20	30	PS200
250	PN10	70	680	839,5	319	350	395	12-Ø23	12-M20	51	PS250
300	PN10	76	755	940	370	400	445	12-Ø23	12-M20	63	PS300
350	PN10	76	922	1137	430	460	505	16-Ø23	16-M20	87	PS350
400	PN10	89	970	1210	480	515	565	16-Ø28	16-M24	117	PS400
500	PN10	127	1330	1621	582	620	670	20-Ø28	20-M24	230	PS500
600	PN10	154	1460	1801	682	725	780	20-Ø31	20-M27	320	PS600

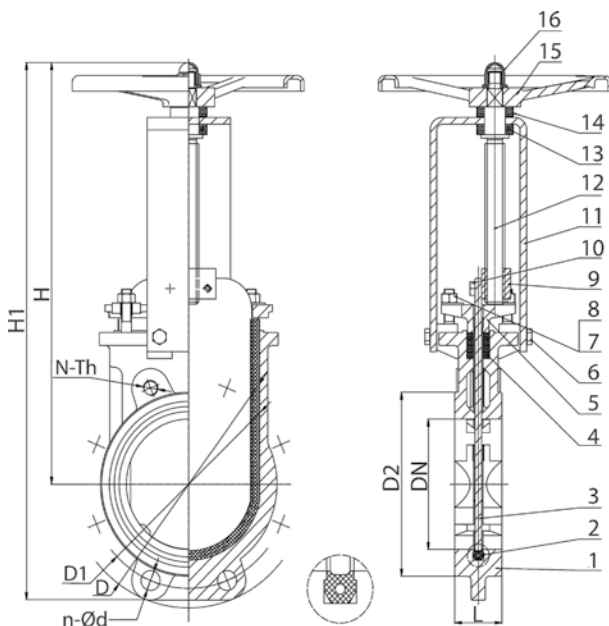

No.	Item	Material
1	Body	EN-GJS-400-15
2	Seat	EPDM
3	Disc	AISI304
4	Sealing	PTFE
5	Gland	WCB
6	Bolt	AISI201
7	Nut/Bolt	AISI201
8	Nut/Bolt	AISI201
9	Stem Nut	Brass
10	Bolt	SS201
11	Yoke	AISI A3
12	Stem	AISI420
13	Bearing	Stainless steel
14	Bearing Cap	AISI A3
15	Handwheel	EN-GJS-400-15
16	Nut	AISI201

All illustrations, technical data, dimensions (in mm) and weights (all weights specified in kg) are non-binding and are subject to change



DOUBLE BALL AIR VALVE series NVD



VALVES



APPLICATION

Air valve for drinking water and neutral liquids up to 80°C

DESIGN FEATURES

The air release component releases entrapped air in pressurized systems
Air & vacuum component admits large volumes of air during drainage and at water column separation

Dynamic design allows for high velocity air discharge while preventing premature closure

Simple and reliable structure, small dimensions, lightweight

TECHNICAL CHARACTERISTICS

Design according to EN1074-4
Maximum working pressure: PN16
Working temperature: 0-80°C
Powder epoxy coating 250 µm thickness

Color RAL5015
Bonnet gasket in NBR
Fully vulcanized ball in EPDM
Flange standard: EN1092-2

DN	H	A	D	D1	D2	Weight	BLUCAST ref. no.
40	208	250	150	110	84	10	NVD040
50	208	250	165	125	99	11.2	NVD050
65	208	250	185	145	118	12	NVD065
80	250	325	200	160	132	21	NVD080
100	250	325	220	180	154	23.5	NVD100
125	344	440	250	210	184	28	NVD125
150	344	440	285	240	210	48.5	NVD150
200	468	612	310	295	265	55	NVD200

No.	Item	Material
1	Body	EN GJS-500-7
2	Ball	ABS/SS304+EPDM
3	Ball	ABS/SS304+EPDM
4	Gasket	NBR
5	Cover	EN GJS-500-7
6	Bolts	Stainless steel
7	Washer	Stainless steel
8	Gasket	NBR
9	Cover	EN GJS-500-7
10	Valve	Stainless steel

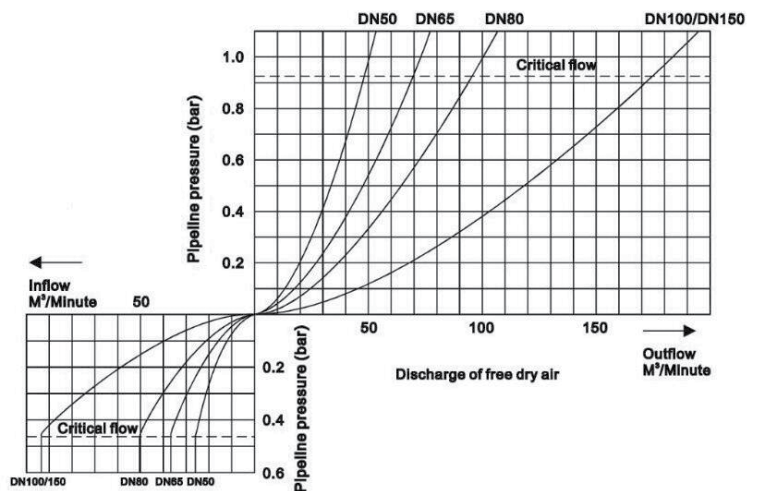
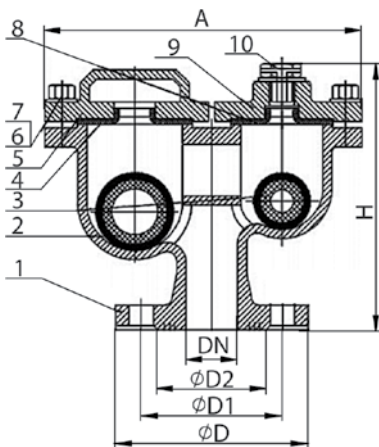

COMBINATION AIR RELEASE VALVE series NVC



APPLICATION

Air valve for drinking water and neutral liquids up to 80°C

DESIGN FEATURES

- Non-slam anti-shock design
- Discharge large air flow from a water pipeline
- Admit large air flow into water pipeline
- Purge entrapped air from pipeline under pressure
- Screen for protection from insects
- Full bore
- Stainless steel float

TECHNICAL CHARACTERISTICS

- Hydrostatic tests according EN-12266-1, class A
- Designed to EN-1074/4 and AWWA C-512
- Flanges to EN-1092/2 or ANSI-150
- Flange drilling acc. PN10, PN16 and PN25 available under request.
- Color RAL5015
- Powder epoxy coating 250 µm thickness



VALVES

DN	Flange drilling	D	K	H	B	n-Ød	KG	BLUCAST ref. no.	No.	Item	Material
50	PN10/16	165	125	305	19	4-Ø19	13.7	NVC050	1	Body	Ductile iron
65	PN10/16	185	145	305	19	4-Ø19	14.5	NVC065	2	Bushing	Stainless steel AISI 304
80	PN10/16	200	160	330	19	8-Ø19	18.4	NVC080	3	Floating ball	Stainless steel AISI 304
100	PN10/16	220	180	370	19	8-Ø19	23.7	NVC100	4	Disc	Stainless steel AISI 304
150	PN10/16	285	240	450	19	8-Ø23	46	NVC150	5	Seal Ring	NBR
200	PN10	340	295	500	20	8-Ø23	83.4	NVC200	6	O ring	NBR
250	PN10	395	350	685	22	12-Ø23	160	NVC250	7	Bonnet	Ductile iron
300	PN10	445	400	780	24.5	12-Ø23	290	NVC300	8	Dustproof screen	Stainless steel AISI 304
									9	Dust cover	Stainless steel AISI 304
									10	Screw	Galvanized carbon steel or AISI304
									11	Bolt	Stainless steel AISI 304
									12	Flat Washer	Stainless steel AISI 304
									13	Guide Rod	Brass
									14	Nut	Stainless steel AISI 304
									15	O ring	NBR
									16	Lock Nut	Brass
									17	Sealing Plug	Silicon
									18	Sealing sleeve	Brass

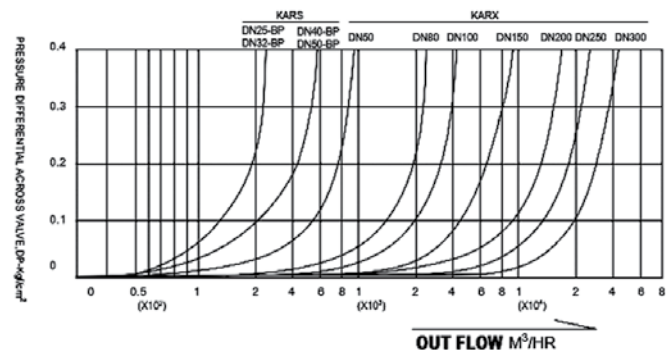
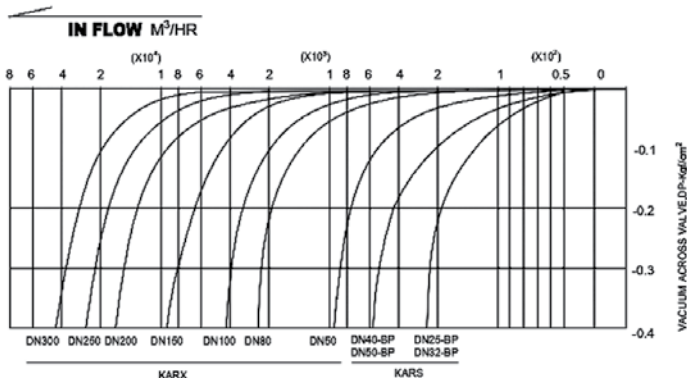
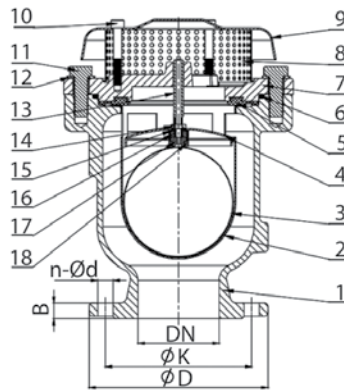
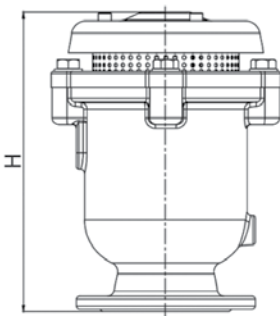

All illustrations, technical data, dimensions (in mm) and weights (all weights specified in kg) are non-binding and are subject to change



SINGLE BALL FLANGED AIR VALVE series NVF



VALVES



APPLICATION

Single ball air valve for drinking water and neutral liquids up to 80°C

DESIGN FEATURES

The air release component releases entrapped air in pressurized systems
 Single orifice, single function
 Universal flange DN40/50/65, PN10/16
 Simple and reliable structure, small dimensions, lightweight

TECHNICAL CHARACTERISTICS

Hydrostatic tests according EN-12266-1, class A
 Designed to EN-1074/4 and AWWA C-512
 Color RAL5015
 Powder epoxy coating 250 µm thickness

DN	Air valve	Weight	BLUCAST ref. no.
50	1"	7.5	NVF0501

No.	Item	Material
1	Flange	Ductile iron
2	Ball valve 1"	Brass
3	Body	Ductile iron
4	Float	ABS
5	Seat	EPDM
6	Hinge Pin	Stainless steel AISI304
7	O ring	NBR
8	Bonnet	Ductile iron
9	Bracket	Brass
10	O ring	NBR
11	O ring	NBR
12	Cap	Brass
13	Bolt	AISI304 stainless steel
14	Washer	AISI304 stainless steel

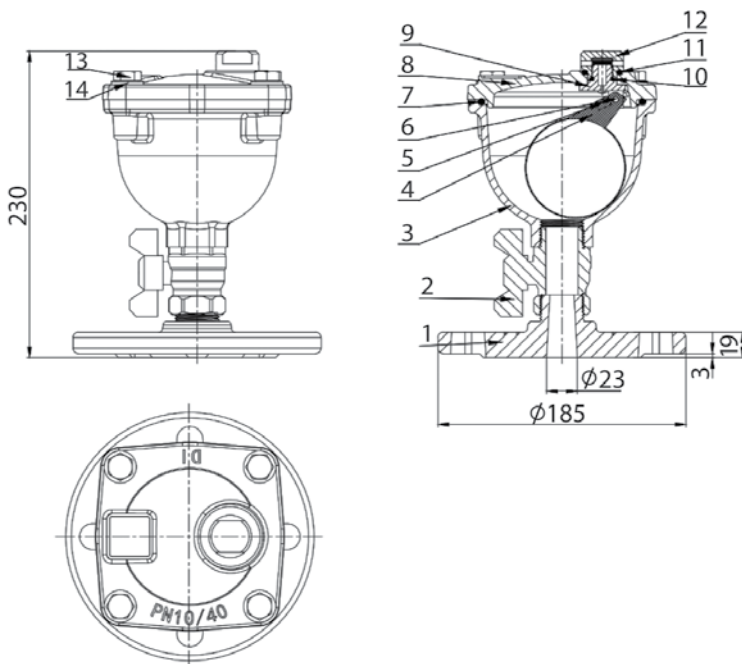

All illustrations, technical data, dimensions (in mm) and weights (all weights specified in kg) are non-binding and are subject to change



SINGLE BALL THREADED AIR VALVE series NVT



APPLICATION

Air valve for drinking water and neutral liquids up to 80°C

DESIGN FEATURES

The air release component releases entrapped air in pressurized systems
Simple and reliable structure, small dimensions, lightweight

TECHNICAL CHARACTERISTICS

Design according to EN1074-4
Maximum working pressure: PN16
Working temperature: 0-80°C
Color RAL5015
Powder epoxy coating 250 µm thickness



VALVES

M	H	D	Weight	BLUCAST ref. no.
1"	145	105	3	NVT25
1 1/4"	145	105	4	NVT32
1 1/2"	172	128	5	NVT40
2"	172	128	6	NVT50

No.	Item	Material
1	Body	EN GJS-500-7
2	Ball	ABS
3	Gasket	NBR
4	Bolts	Zinc plated 4.8 steel or stainless steel
5	Bonnet	EN GJS-500-7
6	Valve	Brass

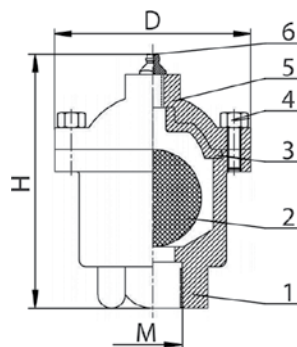

STRAINER series Y



VALVES



APPLICATION

The Y-strainers are installed in water systems to filter out pebbles and other impurities that could damage the equipment

DESIGN FEATURES

- Compact design
- Quick removal of lid for maintenance
- Drain plug enables full drainage without removing the lid

TECHNICAL CHARACTERISTICS

- Face to face dimensions according to EN558-1 series 1 and DIN3202 F1
- Flange connections according to EN1092-2: PN10&PN16
- Color RAL5015
- Working temperature: 0°C-70°C
- Stainless steel bolts
- Powder epoxy coating 250µm thickness

Strainers are designed for installation in horizontal pipelines

Installation in other direction pipelines is permissible if the medium flows from top to bottom

DN	Flange drilling	L	D	D1	D2	n-Ød	Weight	BLUCAST ref. no.
50	PN10/16	230	165	125	102	4-18	8.5	Y050
65	PN10/16	290	185	145	122	4-18	12	Y065
80	PN10/16	310	200	160	138	8-18	15	Y080
100	PN10/16	350	220	180	158	8-18	20	Y100
125	PN10/16	400	250	210	188	8-18	32	Y125
150	PN10/16	480	285	240	212	8-23	45	Y150
200	PN10	600	340	295	268	8-23	76	Y200
250	PN10	730	405	350	320	12-23	97	Y250
300	PN10	850	460	400	370	12-23	142	Y300
350	PN10	980	520	460	429	16-23	190	Y350
400	PN10	1100	580	515	480	16-28	240	Y400
500	PN10	1250	715	620	582	20-28	600	Y500
600	PN10	1450	840	725	682	20-31	890	Y600

*PN16 version available by pre-order

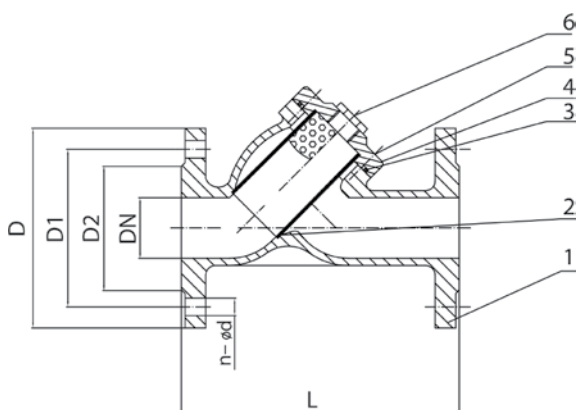

No.	Item	Material
1	Body	EN GJS-500-7
2	Screen	AISI304
3	O ring	EPDM
4	Cover	EN GJS-500-7
5	Bolts	Stainless steel A2
6	Plug	AISI304

UNDERGROUND HYDRANT PN16 series PH



APPLICATION

Underground hydrant for fire protection and drinking water applications

DESIGN FEATURES

Corrosion resistant internal and external parts
 Complete drainage system
 Low closing torque
 Clockwise closing
 100% watertight
 Fully vulcanized valve plug

TECHNICAL CHARACTERISTICS

Flange end connections according to EN1092-2: PN10/PN16
 Product according to EN 1074-1; EN 1074-6; EN 14339
 Bayonet socket according to DIN 3221 "C"
 Maximum working pressure: PN16 / 16 bar
 Working temperature: 0°C - +50°C
 Fully vulcanized wedge in EPDM
 Color RAL5015
 Powder epoxy coating 250 µm thickness
 Beginning of opening <3 turns, full opening after 8 turns

OPERATING



DN	Flange drilling	H	RD	KG	BLUCAST ref. no.
80	PN10/16	527	750	30	PH0800750
80	PN10/16	725	1000	33	PH0801000
80	PN10/16	975	1250	36	PH0801250
80	PN10/16	1225	1500	39	PH0801500
80	PN10/16	1475	1800	42	PH0801800

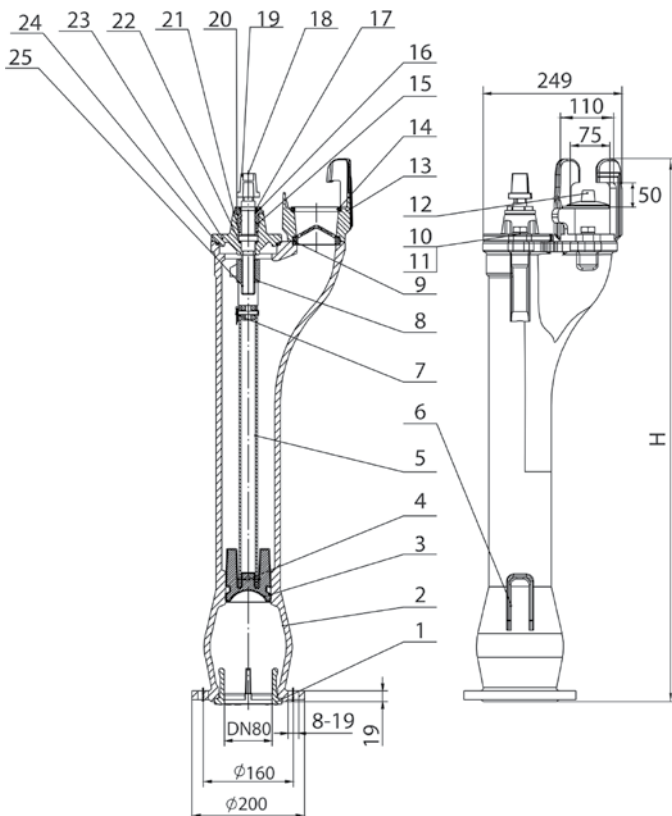

No.	Item	Material
1	Gasket	EPDM+PVC
2	Body	EN-GJS-500-7
3	Wedge	EN-GJS-500-7, EPDM
4	Pin	Stainless steel
5	Stem extension	AISI304
6	Drain cover	PVC
7	Pin	Stainless steel
8	Connecting nut	Brass
9	Deflector	EPDM
10	Bolt	Stainless steel A2
11	Washer	Stainless steel A2
12	Closing lid	PP
13	Bayonet socket	EN-GJS-500-7
14	Gasket	Brass
15	Sealing nut	Brass
16	O rings	EPDM
17	Dust proof ring	EPDM
18	Bolt	Stainless steel A2
19	Square cap	EN-GJS-500-7
20	O ring	EPDM
21	O ring	EPDM
22	Washer	PTFE
23	Upper bonnet	EN-GJS-500-7
24	O ring	EPDM
25	Stem	AISI420

All illustrations, technical data, dimensions (in mm) and weights (all weights specified in kg) are non-binding and are subject to change



ALL FLANGED TEE series T



TECHNICAL CHARACTERISTICS

Flange end connections according to EN1092-2: PN10/PN16

Designed according to EN545

Maximum working pressure: PN16 / 16 bar

Working temperature: 0°C - +70°C

Color RAL5015

Powder epoxy coating 250 µm thickness

Body from ductile iron EN-GJS-500-7

WRAS approved epoxy coating, ACS approved epoxy coating under request

DUCTILE IRON FITTINGS

DN1	DN2	Flange drilling	L	H	e1	e2	Weight	BLUCAST ref. no.	DN1	DN2	Flange drilling	L	H	e1	e2	Weight	BLUCAST ref. no.
50	50	PN10/16	300	150	7	7	9.8	T050050	250	100	PN10	425	270	9	7.2	52.6	T250100
65	50	PN10/16	330	165	7	7	12	T065050	250	100	PN16	425	270	9	7.2	52.6	TP250100
65	65	PN10/16	330	165	7	7	13	T065065	250	150	PN10	485	280	9	7.8	62	T250150
80	50	PN10/16	310	145	7	7	13	T080050	250	150	PN16	485	280	9	7.8	62	TP250150
80	65	PN10/16	330	160	7	7	13.5	T080065	250	200	PN10	540	290	9	8.4	64.8	T250200
80	80	PN10/16	330	165	7	7	11.9	T080080	250	200	PN16	540	290	9	8.4	64.8	TP250200
100	50	PN10/16	320	165	7.2	7	12.7	T100050	250	250	PN10	600	300	9	9	89	T250250
100	65	PN10/16	360	165	7.2	7	13.5	T100065	250	250	PN16	600	300	9	9	89	TP250250
100	80	PN10/16	330	170	7.2	7	15.4	T100080	300	80	PN10	425	295	9.6	7	62	T300080
100	100	PN10/16	360	180	7.2	7.2	15.3	T100100	300	80	PN16	425	295	9.6	7	62	TP300080
125	100	PN10/16	370	195	7.5	7.2	15.8	T125100	300	100	PN10	450	300	9.6	7.2	65	T300100
125	125	PN10/16	400	200	7.5	7.5	16.3	T125125	300	100	PN16	450	300	9.6	7.2	65	TP300100
150	50	PN10/16	335	175	7.8	7	27.8	T150050	300	150	PN10	505	310	9.6	7.8	82	T300150
150	65	PN10/16	440	195	7.8	7	28	T150065	300	150	PN16	505	310	9.6	7.8	82	TP300150
150	80	PN10/16	360	200	7.8	7	28.5	T150080	300	200	PN10	565	320	9.6	8.4	85	T300200
150	100	PN10/16	440	210	7.8	7.2	29.5	T150100	300	200	PN16	565	320	9.6	8.4	85	TP300200
150	150	PN10/16	440	220	7.8	7.8	30.7	T150150	300	250	PN10	620	330	9.6	9	90	T300250
200	50	PN10	365	200	8.4	7	32	T200050	300	300	PN10	680	340	9.6	9.6	100.9	T300300
200	65	PN10	365	215	8.4	7	32.8	T200065	300	300	PN16	680	340	9.6	9.6	100.9	TP300300
200	80	PN10	380	225	8.4	7	30.9	T200080	350	350	PN10	760	380	10.2	10.2	135	T350350
200	100	PN10	400	230	8.4	7.2	35.5	T200100	400	80	PN10	470	355	10.8	7	91	T400080
200	100	PN16	400	230	8.4	7.2	35.5	TP200100	400	100	PN10	490	360	10.8	7.2	91	T400100
200	150	PN10	460	245	8.4	7.8	40.5	T200150	400	150	PN10	550	370	10.8	7.8	97.5	T400150
200	150	PN16	460	245	8.4	7.8	40.5	TP200150	400	200	PN10	610	380	10.8	8.4	113.1	T400200
200	200	PN10	520	260	8.4	8.4	45.4	T200200	400	250	PN10	665	390	10.8	9	125.1	T400250
200	200	PN16	520	260	8.4	8.4	45.4	TP200200	400	300	PN10	725	400	10.8	9.6	138.4	T400300
250	65	PN10	385	260	9	7	45	T250065	400	400	PN10	840	420	10.8	10.8	163.3	T400400
250	80	PN10	405	265	9	7	48	T250080	500	100	PN10	535	400	12	7.2	133.5	T500100
									500	150	PN10	600	410	12	7.8	146.6	T500150
									500	200	PN10	650	415	12	8.4	157.5	T500200
									500	300	PN10	740	450	12	9.6	150	T500300
									500	400	PN10	885	480	12	10.8	216.9	T500400
									500	500	PN10	1000	500	12	12	252	T500500
									600	100	PN10	550	450	13.2	7.2	180.4	T600100
									600	150	PN10	650	455	13.2	7.8	203.8	T600150
									600	200	PN10	700	460	13.2	8.4	211	T600200
									600	300	PN10	810	500	13.2	9.6	250.3	T600300
									600	400	PN10	930	530	13.2	10.8	285.8	T600400
									600	600	PN10	1100	550	13.2	13.2	355	T600600

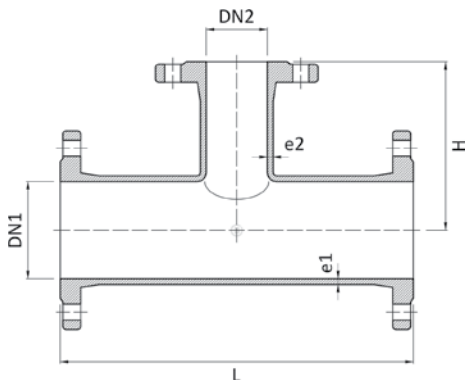

All illustrations, technical data, dimensions (in mm) and weights (all weights specified in kg) are non-binding and are subject to change



ALL FLANGED CROSS series TT



TECHNICAL CHARACTERISTICS

Flange end connections according to EN1092-2
 Drilling of flanges: PN10/16, starting from DN200 - PN10
 Designed according to EN545
 Maximum working pressure: PN16 / 16 bar
 Working temperature: 0°C - +70°C
 Color RAL5015
 Powder epoxy coating 250 µm thickness
 Body from ductile iron EN-GJS-500-7
 WRAS approved epoxy coating,
 ACS approved epoxy coating under request



DUCTILE IRON FITTINGS

DN1	DN2	L	H1	H2	Weight	BLUCAST ref. no.
50	50	300	150	150	14	TT050
65	65	330	165	165	17.5	TT065
80	80	330	165	165	20.1	TT080
100	50	330	165	165	21.5	TT100050
100	80	330	170	170	23	TT100080
100	100	360	180	180	25	TT100100
150	80	360	200	200	33.1	TT150080
150	100	380	205	205	35.1	TT150100
150	150	440	220	220	41.1	TT150
200	100	400	230	230	48.5	TT200100
200	150	460	245	245	54.5	TT200150
200	200	520	260	260	61.5	TT200
200	200	520	260	260	60.9	TTP200
250	100	420	270	270	74.1	TT250100
250	250	600	300	300	102	TT250
300	100	450	300	300	100	TT300100
300	150	500	310	310	108	TT300150
300	200	560	320	320	116	TT300200
300	300	680	340	340	144	TT300
350	350	760	380	380	174	TT350
400	100	490	360	360	149	TT400100
400	150	550	370	370	151	TT400150
400	400	840	420	420	211	TT400
500	500	1000	500	500	299	TT500
600	600	1100	550	550	416	TT600

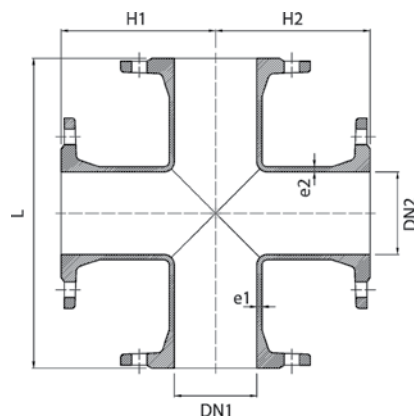

All illustrations, technical data, dimensions (in mm) and weights (all weights specified in kg) are non-binding and are subject to change



DOUBLE FLANGED BEND 90° series Q

DOUBLE FLANGED BEND 45° series FFK



TECHNICAL CHARACTERISTICS

Flange end connections according to EN1092-2: PN10 or PN16
 Designed according to EN545
 Maximum working pressure: PN16 / 16 bar
 Working temperature: 0°C - +70°C
 Color RAL5015
 Powder epoxy coating 250 µm thickness
 Body from ductile iron EN-GJS-500-7
 WRAS approved epoxy coating,
 ACS approved epoxy coating under request

TECHNICAL CHARACTERISTICS

Flange end connections according to EN1092-2: PN10/PN16
 Designed according to EN545
 Maximum working pressure: PN16 / 16 bar
 Working temperature: 0°C - +70°C
 Color RAL5015
 Powder epoxy coating 250 µm thickness
 Body from ductile iron EN-GJS-500-7
 WRAS approved epoxy coating,
 ACS approved epoxy coating under request

DUCTILE IRON FITTINGS

DN	Flange drilling	L	e	Weight	BLUCAST ref. no.
50	PN10/16	150	7	6.1	Q050
65	PN10/16	160	7	8.5	Q065
80	PN10/16	165	7	9.7	Q080
100	PN10/16	180	7.2	11.9	Q100
125	PN10/16	200	7.5	19.6	Q125
150	PN10/16	220	7.8	21	Q150
200	PN10	260	8.4	33.6	Q200
200	PN16	260	8.4	33.6	QP200
250	PN10	350	9	52	Q250
250	PN16	350	9	52	QP250
300	PN10	400	9.6	72	Q300
300	PN16	400	9.6	72	QP300
400	PN10	500	10.4	151	Q400
500	PN10	600	12	190	Q500
600	PN10	700	13.2	286	Q600

DN	Flange drilling	L	e	Weight	BLUCAST ref. no.
50	PN10/16	150	7	7.6	FFK050
65	PN10/16	165	7	8.7	FFK065
80	PN10/16	130	7	9.3	FFK080
100	PN10/16	140	7.2	10.8	FFK100
150	PN10/16	160	7.8	19	FFK150
200	PN10	180	8.4	28	FFK200
250	PN10	245	9	46	FFK250
300	PN10	275	9.6	64	FFK300
400	PN10	325	10.4	96	FFK400
500	PN10	375	12	145	FFK500
600	PN10	400	13.2	211	FFK600

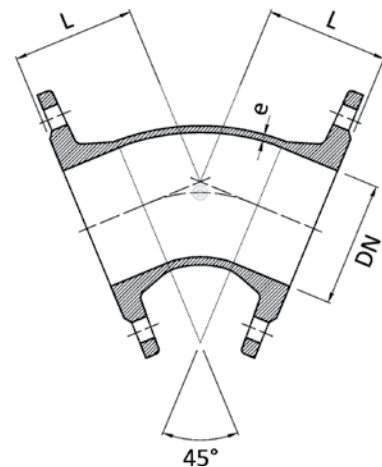
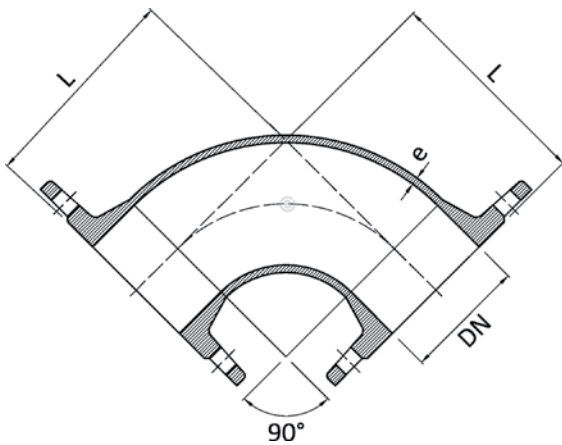

All illustrations, technical data, dimensions (in mm) and weights (all weights specified in kg) are non-binding and are subject to change



DUCKFOOT BEND 90° series N



TECHNICAL CHARACTERISTICS

Flange end connections according to EN1092-2: PN10/PN16
 Designed according to EN545
 Maximum working pressure: PN16 / 16 bar
 Working temperature: 0°C - +70°C
 Color RAL5015
 Powder epoxy coating 250 µm thickness
 Body from ductile iron EN-GJS-500-7
 WRAS approved epoxy coating,
 ACS approved epoxy coating under request

STUDED REDUCER FLANGE series XR



TECHNICAL CHARACTERISTICS

Flange end connections according to EN1092-2
 Drilling of flanges: PN10/16, starting from DN200 - PN10
 Maximum working pressure: PN16 / 16 bar
 Working temperature: 0°C - +70°C
 Color RAL5015
 Powder epoxy coating 250 µm thickness
 Body from ductile iron EN-GJS-500-7
 WRAS approved epoxy coating
 Bolts, nuts and washers - hot dip galvanized 8.8 carbon steel



DN	Flange drilling	L	C	d	e	Weight	BLUCAST ref. no.
50	PN10/16	150	95	160	7	7.2	N050
80	PN10/16	165	110	180	7	12.2	N080
100	PN10/16	180	125	200	7.2	15	N100
150	PN10/16	220	160	250	7.8	30.5	N150
200	PN10	260	190	300	8.4	47.5	N200
250	PN10	350	225	350	9	76.8	N250
300	PN10	400	255	400	9.6	109	N300
400	PN10	500	320	500	10.8	185	N400
500	PN10	600	385	600	12	292	N500
600	PN10	700	450	700	13.2	446	N600

DN1	DN2	Flange drilling	L	Screws	Weight	BLUCAST ref. no.
65	50	PN10/16	45	D	5.6	XR065050
80	50	PN10/16	30	D	5.7	XR080050
80	65	PN10/16	30	D	4.9	XR080065
100	50	PN10/16	30	D	5.4	XR100050
100	65	PN10/16	30	D	5.8	XR100065
100	80	PN10/16	45	D	8.7	XR100080
125	80	PN10/16	31	D	7.5	XR125080
125	100	PN10/16	42	D	8.9	XR125100
150	50	PN10/16	33	S	11	XR150050
150	65	PN10/16	30	S	9.1	XR150065
150	80	PN10/16	30	S	8.8	XR150080
150	100	PN10/16	30	D	11.1	XR150100
150	125	PN10/16	45	D	11.8	XR150125
200	65	PN10	33	S	13.5	XR200065
200	80	PN10	33	S	13.3	XR200080
200	100	PN10	33	S	13.2	XR200100
200	150	PN10	38	S	15	XR200150
250	100	PN10	31	D	21.9	XR250100
250	150	PN10	40	S	26.8	XR250150
250	200	PN10	50	D	22.7	XR250200
300	80	PN10	31	D	26.5	XR300080
300	100	PN10	40	D	26	XR300100
300	150	PN10	31	D	25.3	XR300150
300	200	PN10	32	S	24.1	XR300200
300	250	PN10	33	D	31.2	XR300250
400	100	PN10	38	S	53.8	XR400100
400	150	PN10	38	S	50.2	XR400150
400	200	PN10	38	S	46.2	XR400200
400	250	PN10	38	S	40.3	XR400250
400	300	PN10	39	S	39.8	XR400300
500	100	PN10	47	S	116	XR500100
500	200	PN10	47	S	91	XR500200
500	300	PN10	47	S	84.4	XR500300
500	400	PN10	47	S	100	XR500400

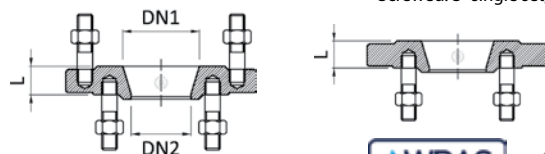
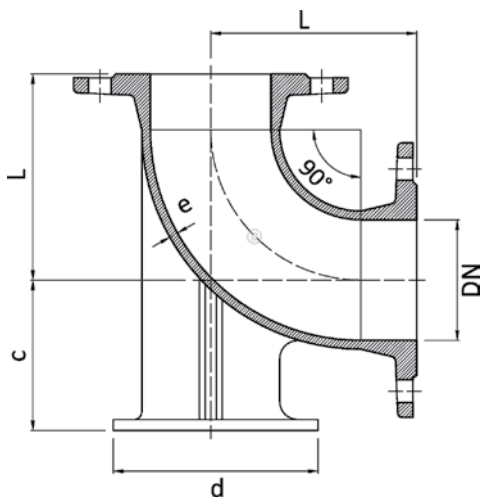

Screwed: S- single set, D- double set



All illustrations, technical data, dimensions (in mm) and weights (all weights specified in kg) are non-binding and are subject to change

DOUBLE FLANGED PIPE series FF



TECHNICAL CHARACTERISTICS

Flange end connections according to EN1092-2

Designed according to EN545

Maximum working pressure: PN16 / 16 bar

Working temperature: 0°C - +70°C

Color RAL5015

Powder epoxy coating 250 µm thickness

Drilling of flanges: PN10/16, starting from DN200 - PN10

Body from ductile iron EN-GJS-500-7

WRAS approved epoxy coating,

ACS approved epoxy coating under request

DN	Flange drilling	L	e	Weight	BLUCAST ref. no.	DN	Flange drilling	L	e	Weight	BLUCAST ref. no.
50	PN10/16	100	7	4	FF050100	150	PN10/16	100	7.8	14	FF150100
50	PN10/16	200	7	5.5	FF050200	150	PN10/16	200	7.8	16	FF150200
50	PN10/16	300	7	7	FF050300	150	PN10/16	300	7.8	19	FF150300
50	PN10/16	400	7	8.5	FF050400	150	PN10/16	400	7.8	21	FF150400
50	PN10/16	500	7	11	FF050500	150	PN10/16	500	7.8	24	FF150500
50	PN10/16	1000	7	18	FF0501000	150	PN10/16	1000	7.8	38	FF1501000
65	PN10/16	200	7	9	FF065200	200	PN10	100	8.4	19	FF200100
65	PN10/16	300	7	10	FF065300	200	PN10	200	8.4	22	FF200200
65	PN10/16	500	7	12.7	FF065500	200	PN10	300	8.4	26	FF200300
80	PN10/16	100	7	7.7	FF080100	200	PN10	400	8.4	30	FF200400
80	PN10/16	200	7	9	FF080200	200	PN10	500	8.4	34	FF200500
80	PN10/16	300	7	11	FF080300	200	PN10	1000	8.4	54	FF2001000
80	PN10/16	400	7	12.5	FF080400	250	PN10	200	9	29	FF250200
80	PN10/16	500	7	14	FF080500	250	PN10	300	9	35	FF250300
80	PN10/16	1000	7	22.3	FF0801000	250	PN10	500	9	45	FF250500
100	PN10/16	100	7.2	8.8	FF100100	250	PN10	1000	9	72	FF2501000
100	PN10/16	200	7.2	10.5	FF100200	300	PN10	100	9.6	31	FF300100
100	PN10/16	300	7.2	12	FF100300	300	PN10	200	9.6	39	FF300200
100	PN10/16	400	7.2	14	FF100400	300	PN10	300	9.6	45	FF300300
100	PN10/16	500	7.2	15.5	FF100500	300	PN10	400	9.6	52	FF300400
100	PN10/16	1000	7.2	25	FF1001000	300	PN10	500	9.6	59	FF300500
						300	PN10	1000	9.6	93	FF3001000

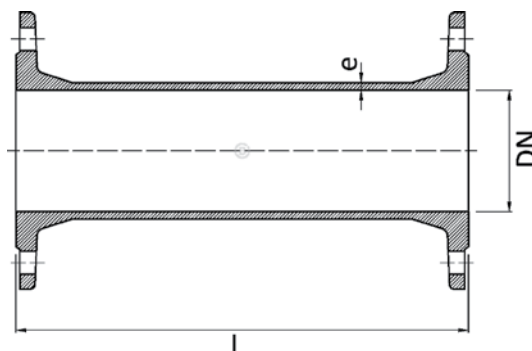

DOUBLE FLANGED TAPER series FFR



TECHNICAL CHARACTERISTICS

Flange end connections according to EN1092-2: PN10/PN16
Designed according to EN545

Maximum working pressure: PN16 / 16 bar

Working temperature: 0°C - +70°C

Color RAL5015

Powder epoxy coating 250 µm thickness

Body from ductile iron EN-GJS-500-7

WRAS approved epoxy coating,

ACS approved epoxy coating under request



DN1	DN2	Flange drilling	L	e1	e2	Weight	BLUCAST ref. no.	DN1	DN2	Flange drilling	L	e1	e2	Weight	BLUCAST ref. no.
65	50	PN10/16	200	7	7		FFR065050	250	150	PN10	300	9	7.8	26	FFR250150
80	50	PN10/16	200	7	7	5.9	FFR080050	250	150	PN16	300	9	7.8	26	FFRP250150
80	65	PN10/16	200	7	7	6	FFR080065	250	200	PN10	300	9	8.4	29.5	FFR250200
100	50	PN10/16	200	7.2	7	6.8	FFR100050	250	200	PN16	300	9	8.4	29.5	FFRP250200
100	65	PN10/16	200	7.2	7	8.8	FFR100065	300	100	PN10	300	9.6	7.2	30.3	FFR300100
100	80	PN10/16	200	7.2	7	8	FFR100080	300	100	PN16	300	9.6	7.2	30.3	FFRP300100
125	100	PN10/16	200	7.4	7	8.5	FFR125100	300	150	PN10	300	9.6	7.8	32.1	FFR300150
150	50	PN10/16	200	7.8	7	9.7	FFR150050	300	200	PN10	300	9.6	8.4	33	FFR300200
150	65	PN10/16	200	7.8	7	9.8	FFR150065	300	200	PN16	300	9.6	8.4	33	FFRP300200
150	80	PN10/16	200	7.8	7	10	FFR150080	300	250	PN10	300	9.6	9	34	FFR300250
150	100	PN10/16	200	7.8	7.2	10.1	FFR150100	300	250	PN16	300	9.6	9	34	FFRP300250
150	125	PN10/16	200	7.8	7.5	17.2	FFR150125	400	100	PN10	300	10.8	9	51	FFR400100
200	80	PN10	300	8.4	7	17.5	FFR200080	400	150	PN10	300	10.8	9	51	FFR400150
200	80	PN16	300	8.4	7	17.5	FFRP200080	400	200	PN10	300	10.8	9	73.5	FFR400200
200	100	PN10	300	8.4	7.2	21.9	FFR200100	400	250	PN10	300	10.8	9	50	FFR400250
200	100	PN16	300	8.4	7.2	21.9	FFRP200100	400	300	PN10	300	10.8	9	58	FFR400300
200	150	PN10	300	8.4	7.8	22.7	FFR200150	500	300	PN10	300	12	12	110	FFR500300
200	150	PN16	300	8.4	7.8	22.7	FFRP200150	500	400	PN10	300	12	12	94	FFR500400
250	100	PN10	300	9	7.2	24.2	FFR250100	600	300	PN10	400	13.2	13.2	152	FFR600300
250	100	PN16	300	9	7.2	24.2	FFRP250100	600	400	PN10	300	13.2	13.2	142	FFR600400

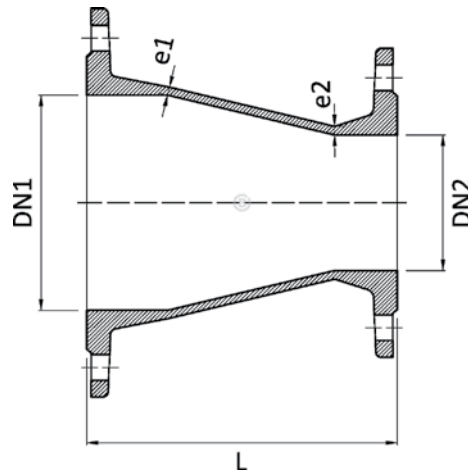

All illustrations, technical data, dimensions (in mm) and weights (all weights specified in kg) are non-binding and are subject to change



BLIND FLANGE series X

THREADED BLIND FLANGE series XS



TECHNICAL CHARACTERISTICS

Flange end connections according to EN1092-2: PN10/PN16
 Designed according to EN545
 Maximum working pressure: PN16 / 16 bar
 Working temperature: 0°C - +70°C
 Color RAL5015
 Powder epoxy coating 250 µm thickness
 Body from ductile iron EN-GJS-500-7
 WRAS approved epoxy coating,
 ACS approved epoxy coating under request

TECHNICAL CHARACTERISTICS

Flange end connections according to EN1092-2: PN10/PN16
 Designed according to EN545
 Maximum working pressure: PN16 / 16 bar
 Working temperature: 0°C - +70°C
 Color RAL5015
 Powder epoxy coating 250 µm thickness
 Body from ductile iron EN-GJS-500-7
 Universal flange drilling PN10/16

DUCTILE IRON FITTINGS

DN	Flange drilling	D	L	Weight	BLUCAST ref. no.
50	PN10/16	165	19	2.4	X050
65	PN10/16	185	19	2.8	X065
80	PN10/16	200	19	3.5	X080
100	PN10/16	220	19	4.1	X100
125	PN10/16	250	19	5.6	X125
150	PN10/16	285	19	8.1	X150
200	PN10	340	20	9	X200
200	PN16	340	20	9	XP200
250	PN10	400	22	18.7	X250
250	PN16	400	22	18.7	XP250
300	PN10	455	24.5	23.5	X300
300	PN16	455	24.5	23.5	XP300
400	PN10	565	24.5	41.1	X400
500	PN10	670	26.5	61.1	X500
600	PN10	780	30	94.1	X600

DN	Flange drilling	G	D	L	Weight	BLUCAST ref. no.
50	PN10/16	1"	165	17	2.5	XS0501
50	PN10/16	1 1/4"	165	17	2.5	XS050114
50	PN10/16	1 1/2"	165	17	2.5	XS0502
50	PN10/16	2"	165	17	2.5	XS0502
65	PN10/16	1"	185	19	2.8	XS0651
65	PN10/16	1 1/4"	185	19	2.8	XS065114
65	PN10/16	2"	185	19	2.8	XS0652
80	PN10/16	1"	200	19	3	XS0801
80	PN10/16	1 1/4"	200	19	3	XS080114
80	PN10/16	2"	200	19	3	XS0802
100	PN10/16	1"	220	21	4	XS1001
100	PN10/16	1 1/4"	220	21	4	XS100114
100	PN10/16	1 1/2"	220	21	4	XS100112
100	PN10/16	2"	220	21	4	XS1002
150	PN10/16	1"	285	23	7	XS1501
150	PN10/16	2"	285	23	7	XS1502
200	PN10/16	2"	340	23	14	XS2002
250	PN10/16	2"	400	25	19	XS2502
300	PN10/16	2"	455	25	30	XS3002

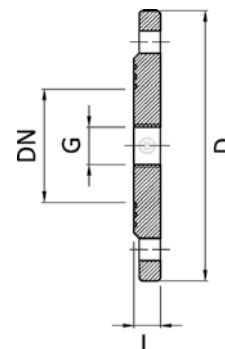
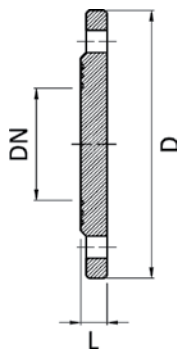

All illustrations, technical data, dimensions (in mm) and weights (all weights specified in kg) are non-binding and are subject to change

DISMANTLING JOINT series DJ



TECHNICAL CHARACTERISTICS

Flange end connections according to EN1092-2: PN10/PN16
 Designed according to EN545
 Maximum working pressure: PN16 / 16 bar
 Working temperature: 0°C - +70°C
 Color RAL5015
 Powder epoxy coating 250 µm thickness
 Body from ductile iron EN-GJS-500-7
 Bolts, nuts and washers - hot dip galvanized 8.8 carbon steel
 or stainless steel A2 option available
 Gasket - EPDM. NBR option available



Nominal size	Flange drilling	D	L1 min	L1 max	Bolt	Quantity & hole size	Weight	BLUCAST ref. no.
DN50	PN10/16	165	170	220	M16	4 x 19	9.6	DJ050
DN65	PN10/16	185	170	220	M16	4 x 19	12.6	DJ065
DN80	PN10/16	200	190	240	M16	8 x 19	15.8	DJ080
DN100	PN10/16	220	200	250	M16	8 x 19	18	DJ100
DN125	PN10/16	250	200	250	M16	8 x 19	22	DJ125
DN150	PN10/16	285	200	250	M20	8 x 23	28.7	DJ150
DN200	PN10	340	200	250	M20	8 x 23	35.5	DJ200
DN200	PN16	340	200	250	M20	12 x 23	41.5	DJP200
DN250	PN10	400	210	260	M20	12 x 23	53.1	DJ250
DN250	PN16	400	210	260	M24	12 x 28	58.3	DJP250
DN300	PN10	455	220	270	M20	12 x 23	61.6	DJ300
DN300	PN16	455	220	270	M24	12 x 28	74.5	DJP300
DN350	PN10	505	230	280	M20	16 x 23	82.5	DJ350
DN400	PN10	565	240	290	M24	16 x 28	95	DJ400
DN500	PN10	670	260	310	M24	20 x 28	126.2	DJ500
DN600	PN10	780	280	330	M27	20 x 31	170	DJ600
DN700	PN10	895	290	340	M27	24 x 31	235	DJ700
DN800	PN10	1015	300	350	M30	24 x 34	248	DJ800
DN900	PN10	1115	310	360	M30	28 x 34	327	DJ900
DN1000	PN10	1230	315	365	M33	28 x 37	354	DJ1000
DN1200	PN10	1455	350	400	M36	32 x 40	507	DJ1200
DN1400	PN10	1675	370	420	M39	36 x 43	1190	DJ1400
DN1600	PN10	1915	370	420	M45	40 x 49	1436	DJ1600
DN1800	PN10	2115	390	440	M45	44 x 49	1880	DJ1800
DN2000	PN10	2325	410	460	M45	48 x 49	2206	DJ2000
DN2200	PN10	2550	450	500	M52	52 x 56	2800	DJ2200

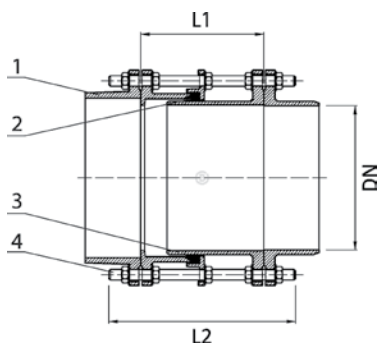

No.	Item	Material
1	Body	Ductile iron EN-GJS-500-7
2	Gasket	EPDM
3	Body	Ductile iron EN-GJS-500-7
4	Bolts	8.8 steel hot dip galvanized

All illustrations, technical data, dimensions (in mm) and weights (all weights specified in kg) are non-binding and are subject to change



FLANGE ADAPTOR FOR PE/PVC PIPES series APZ

COUPLING FOR PE/PVC PIPES series MPZ



APPLICATION

Flange adaptors dedicated for PE and PVC pipes

DESIGN FEATURES

Restrained connection with brass ring prevents axial movement of the pipe

TECHNICAL CHARACTERISTICS

Flange end connections according to EN1092-2: PN10&PN16
 Maximum working pressure: PN16 / 16 bar
 Working temperature: 0°C - +70°C
 Color RAL5015
 Powder epoxy coating 250 µm thickness
 Bolts, nuts and washers - A2 stainless steel



APPLICATION

Restrained couplings dedicated for PE and PVC pipes

DESIGN FEATURES

Restrained connection with brass ring prevents axial movement of the pipe

TECHNICAL CHARACTERISTICS

Maximum working pressure: PN16 / 16 bar
 Working temperature: 0°C - +70°C
 Color RAL5015
 Powder epoxy coating 250 µm thickness
 Bolts, nuts and washers: A2 stainless steel

DN	Flange drilling	DE	L	D	b	E	KG	BLUCAST ref. no.
50	PN10/16	63	90	165	19	80	4	APZ050063
60	PN10/16	75	92	175	19	82	4.2	APZ060075
65	PN10/16	63	90	185	19	80	4.2	APZ065063
65	PN10/16	75	92	185	19	82	4.2	APZ065075
80	PN10/16	75	92	200	19	82	5	APZ080075
80	PN10/16	90	95	200	19	85	5.1	APZ080090
100	PN10/16	90	95	220	19	85	5.5	APZ100090
100	PN10/16	110	95	220	19	85	5.7	APZ100110
100	PN10/16	125	97	220	19	87	6.4	APZ100125
125	PN10/16	110	95	250	19	85	6.7	APZ125110
125	PN10/16	125	97	250	19	87	6.9	APZ125125
125	PN10/16	140	105	250	19	95	8.8	APZ125140
150	PN10/16	160	115	285	19	105	9.8	APZ150160
150	PN10/16	180	125	285	19	115	13	APZ150180
200	PN10/16	200	135	340	20	125	13.1	APZ200200
200	PN10/16	225	138	340	20	128	13.8	APZ200225
250	PN10/16	250	155	400	22	145	19.3	APZ250250
250	PN10/16	280	158	400	22	148	24.9	APZ250280
300	PN10/16	315	184	455	25	174	26.8	APZ300315
400	PN10/16	400	245	580	25	232	48.0	APZ400400

No.	Item	Material
1	Bracket	Ductile iron EN-GJS-500-7
2	Body	Ductile iron EN-GJS-500-7
3	Bolt	AISI306
4	Locking ring	Brass
5	Sealing gasket	EPDM

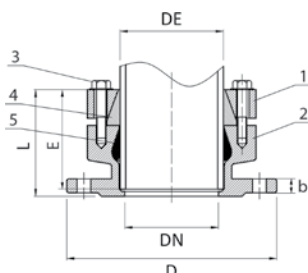

DE	L	D	L1	KG	BLUCAST ref. no.
63	171	124	80	2.6	MPZ063
75	175	138	82	3.8	MPZ075
90	181	152	85	5.1	MPZ090
110	181	172	85	5.7	MPZ110
125	185	193	87	7.1	MPZ125
160	221	236	105	11.5	MPZ160
200	261	284	125	15	MPZ200
225	265	314	128	17.3	MPZ225
250	300	347	145	21	MPZ250
315	358	422	174	37.5	MPZ315

No.	Item	Material
1	Bracket	Ductile iron EN-GJS-500-7
2	Body	Ductile iron EN-GJS-500-7
3	Bolt	AISI306
4	Locking ring	Brass
5	Sealing gasket	EPDM

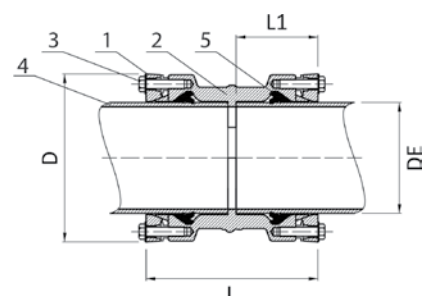

UNIMAX UNIVERSAL ADAPTOR series AUN



APPLICATION

Universal flange adaptor is used for connecting various pipe materials with flanged fittings

DESIGN FEATURES

Large tolerance
Universal drilling for compatibility with both PN10 and PN16
The bolt ends are protected with plastic caps

TECHNICAL CHARACTERISTICS

Flange end connections according to EN1092-2: PN10/PN16
Maximum working pressure: PN16 / 16 bar
Working temperature: 0°C - +70°C
Color RAL5015
Powder epoxy coating 250 µm thickness
Bolts, nuts and washers - carbon steel 8.8 hot dip galvanized
Maximum angular deflection - 4°

UNIMAX UNIVERSAL COUPLING series MUN



APPLICATION

Universal couplings are used for connecting various pipes

DESIGN FEATURES

Large tolerance
The bolt ends are protected with plastic caps

TECHNICAL CHARACTERISTICS

Maximum working pressure: PN16 / 16 bar
Working temperature: 0°C - +70°C
Color RAL5015
Powder epoxy coating 250 µm thickness
Bolts, nuts and washers - carbon steel 8.8 hot dip galvanized
Maximum angular deflection at each end - 4°



DN	DE	D	H	Bolts	Bolt qty.	KG	BLUCAST ref. no.
50	57-74	164	75	M12x120	4	3	AUN050
65	63-85	182	75	M12x120	4	3.8	AUN065
80	85-107	192	75	M12x120	4	4	AUN080
100	107-132	224	75	M12x120	4	5	AUN100
125	132-158	246	75	M12x120	4	6.2	AUN125
150	158-184	283	75	M12x120	4	6.5	AUN150
175	189-212	333	75	M12x140	4	8.4	AUN175
200	200-225	333	75	M12x140	4	10.2	AUN200225
200	218-244	333	75	M12x140	4	8.4	AUN200
225	243-269	375	85	M12x140	6	11.3	AUN225
250	266-295	394	85	M12x140	6	11.4	AUN250
300	315-349	440	85	M12x140	6	14.6	AUN300
350	351-378	481	111	M14x180	8	29	AUN350
400	400-420	526	111	M14x180	8	31.2	AUN400420
400	417-437	536	111	M14x180	8	32.5	AUN400
500	500-532	715	113	M16x180	10	51	AUN500532
500	526-546	618	113	M14x180	10	47	AUN500
600	630-650	734	115	M14x180	10	63	AUN600

DN	DE	D	H	Bolts	Bolt qty.	KG	BLUCAST ref. no.
50	57-74	164	100	M12x180	2	3.2	MUN050
65	63-85	182	100	M12x180	2	3.7	MUN065
80	85-107	192	100	M12x180	4	4.3	MUN080
100	107-132	224	100	M12x180	4	5.3	MUN100
125	132-158	246	110	M12x190	4	6.4	MUN125
150	158-184	283	110	M12x190	4	7.2	MUN150
175	192-210	304	110	M12x190	4	9	MUN175
200	200-225	333	130	M12x210	4	9.7	MUN200225
200	218-244	333	130	M12x210	4	10.3	MUN200
225	243-269	375	130	M12x210	4	12	MUN225
250	266-295	394	130	M12x220	6	13.7	MUN250
300	315-349	440	130	M12x220	6	17.8	MUN300
350	351-378	481	130	M14x250	8	27	MUN350
400	417-437	536	130	M14x250	8	28	MUN400
500	526-546	618	130	M14x250	10	38.5	MUN500
600	630-650	734	130	M14x250	10	59	MUN600

No.	Item	Material
1	Bracket	Ductile iron EN-GJS-500-7
2	Body	Ductile iron EN-GJS-500-7
3	Bolt	8.8 carbon steel hot dip galvanized
4	Sealing gasket	EPDM

No.	Item	Material
1	Bracket	Steel
2	Body	Ductile iron EN-GJS-500-7
3	Bolt	8.8 carbon steel hot dip galvanized
4	Sealing gasket	EPDM

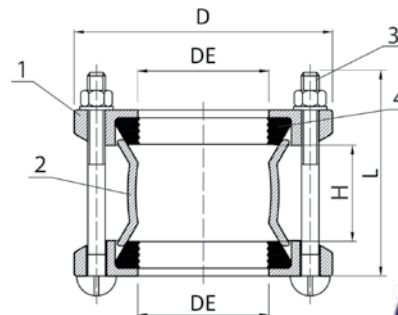
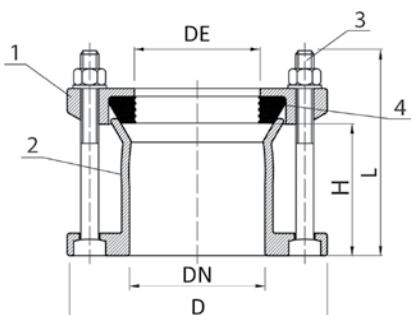

All illustrations, technical data, dimensions (in mm) and weights (all weights specified in kg) are non-binding and are subject to change



MAXIGRIP UNIVERSAL ADAPTOR series AGRIP



APPLICATION

Restrained universal flange adaptor provides reliable connection to various types of pipe where tension resistance is required

DESIGN FEATURES

Tensile resistant
 Large tolerance
 Suitable for ductile iron, steel, PE, PVC, AC pipes
 Universal drilling for compatibility with both PN10 and PN16
 Angular deflection up to 4°
 Corrosion resistant construction

TECHNICAL CHARACTERISTICS

Mechanical locking by metal inserts to avoid pipes axial movement
 Flange end connections according to EN1092-2: PN10/PN16
 Maximum working pressure: PN16 / 16 bar
 Working temperature: -10°C - +70°C
 Body, end ring EN GJS450-12
 Gaskets - EPDM (NBR option available)
 Bolts, nuts and washers - carbon steel 8.8 hot dip galvanized (other options available)
 Galvanized carbon steel tension locks acc. to EN10025
 Epoxy powder coating acc. to DIN30677 - minimum 250 µm thickness
 Color RAL5015
 Tested acc. to EN14525

DN	D	DE	L	Weight	BLUCAST ref. no.	No.	Item	Material
50	187	46-70	170	6.50	AGRIP050	1	Bracket	EN GJS-450-12
65	212	70-95	195	7.00	AGRIP065	2	Plastic tension ring	Plastic
80	240	88-123	215	8.00	AGRIP080	3	Gasket	EPDM
100	260	108-143	225	10.90	AGRIP100	4	Body	EN GJS-450-12
125	285	133-168	225	13.20	AGRIP125	5	Grippers	Carbon steel, zinc coated
150	311	159-194	225	17.50	AGRIP150	6	Bolts, nuts, washers	Carbon steel 8.8
200	370	200-235	245	23.50	AGRIP200			
250	420	250-285	265	37	AGRIP250			
300	485	315-350	275	47	AGRIP300			

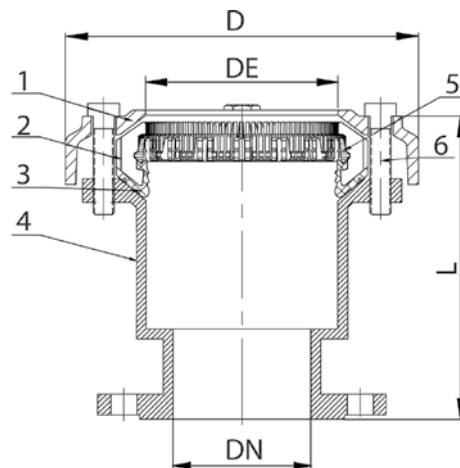

All illustrations, technical data, dimensions (in mm) and weights (all weights specified in kg) are non-binding and are subject to change



MAXIGRIP UNIVERSAL COUPLING series MGRIP



APPLICATION

Restrained universal coupling provides reliable connection to various types of pipes where tension resistance is required

DESIGN FEATURES

Tensile resistant
 Large tolerance
 Suitable for ductile iron, steel, PE, PVC, AC pipes
 Independent clamping on both sides
 Angular deflection up to 4°
 Corrosion resistant construction

TECHNICAL CHARACTERISTICS

Mechanical locking by metal inserts to avoid pipe axial movement
 Maximum working pressure: PN16 / 16 bar
 Working temperature: -10°C - +70°C
 Gasket - EPDM (NBR option available)
 Bolts, nuts and washers - carbon steel 8.8 hot dip galvanized (other options available)
 Galvanised carbon steel tension locks acc. to EN10025
 Epoxy powder coating acc. to DIN30677 - minimum 250 µm thickness
 Color RAL5015
 Tested acc. to EN14525

DN	D	DE	L	Weight	BLUCAST ref. no.
50	187	46-70	240	7.20	MGRIP050
65	212	70-95	240	8.60	MGRIP065
80	240	88-123	250	10	MGRIP080
100	260	108-143	250	13	MGRIP100
125	285	133-168	260	16	MGRIP125
150	311	159-194	260	17	MGRIP150
200	370	200-235	295	22	MGRIP200
250	420	250-285	305	33	MGRIP250
300	485	315-350	315	41	MGRIP300

No.	Item	Material
1	Bracket	EN GJS-450-12
2	Plastic tension ring	Plastic
3	Gasket	EPDM
4	Body	EN GJS-450-12
5	Grippers	Carbon steel, zinc coated
6	Bolts, nuts, washers	Carbon steel 8.8

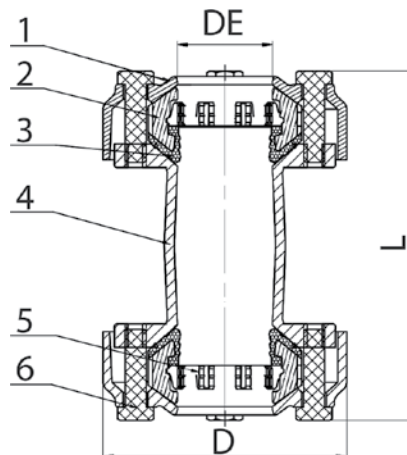

All illustrations, technical data, dimensions (in mm) and weights (all weights specified in kg) are non-binding and are subject to change

FLANGE ADAPTOR FOR PE/PVC PIPES series AQZ

FLANGE ADAPTOR FOR PE/PVC PIPES series APA

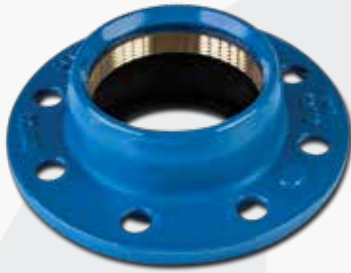

APPLICATION

Flange adaptors dedicated for PE and PVC pipes

DESIGN FEATURES

Quick restrained connection with brass ring prevents axial movement of the pipe

TECHNICAL CHARACTERISTICS

Flange end connections according to EN1092-2: PN10&PN16
 Maximum working pressure: PN16 / 16 bar
 Working temperature: 0°C - +70°C
 Color RAL5015
 Powder epoxy coating 250 µm thickness



APPLICATION

Flange adaptors dedicated for PE and PVC pipes

DESIGN FEATURES

Restrained connection with locking teeth prevents axial movement of the pipe

TECHNICAL CHARACTERISTICS

Flange end connections according to EN1092-2: PN10
 Maximum working pressure: PN16 / 16 bar
 Working temperature: 0°C - +70°C
 Color RAL5015
 Powder epoxy coating 250 µm thickness
 Bolts and nuts - 4.8 steel hot dip galvanized

DN	Flange drilling	DE	H	D	D1	KG	BLUCAST ref. no.
50	PN10/16	63	45	165	125	2.5	AQZ050063
60-65	PN10/16	63	45	185	125	2.5	AQZ065063
60-65	PN10/16	75	45	185	145	2.6	AQZ065075
80	PN10/16	90	53	200	160	3.3	AQZ080090
100	PN10/16	110	56	220	180	3.5	AQZ100110
125	PN10/16	125	60	250	210	4	AQZ125125
150	PN10/16	160	69	285	240	6.2	AQZ150160
200	PN10/16	200	74	340	295	8.5	AQZ200200
200	PN10/16	225	74	340	295	8.7	AQZ200225
250	PN10/16	250	85	400	355	9	AQZ250250
300	PN10/16	315	95	455	410	11	AQZ300315
400	PN10/16	400	105	565	515	14	AQZ400400

DN	Flange drilling	DE	L	D	B	KG	BLUCAST ref. no.
300	PN10	355	277	455	487	31,4	APA300355
350	PN10	355	285	505	487	35,2	APA350355
400	PN10	400	285	565	532	43,7	APA400
400	PN10	455	285	565	632	52,2	APA400455
450	PN10	455	285	610	632	55	APA450
500	PN10	500	285	670	632	59	APA500
600	PN10	630	285	780	762	72,2	APA600

No.	Item	Material
1	Body	Ductile iron EN-GJS-500-7
2	Locking ring	Brass
3	Sealing gasket	EPDM

No.	Item	Material
1	Restraining tooth	4.8 steel hot dip galvanized
2	Bolt	4.8 steel hot dip galvanized
3	Bracket	EN-GJS-500-7
4	Gasket	EPDM
5	Bolt	4.8 steel hot dip galvanized
6	Body	EN-GJS-500-7

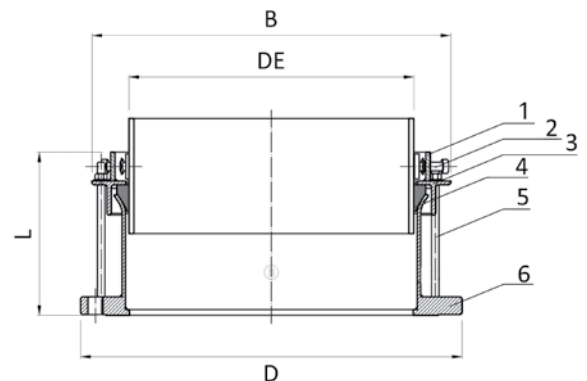
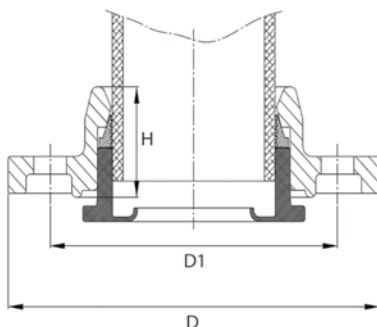

FLANGED SADDLE WITH SS BAND FOR DI PIPES series BKF



APPLICATION

BLUCAST saddles for ductile iron pipes are easy to mount, maintenance free and designed for long life.

TECHNICAL CHARACTERISTICS

Flange end connections according to EN1092-2: PN10/PN16

Designed according to EN545

Maximum working pressure: PN16 / 16 bar

Working temperature: 0°C - +70°C

Color RAL5015

Powder epoxy coating 250 µm thickness

Body from ductile iron EN-GJS-500-7



TAPPING SADDLES

DN	DE range	Outlet DN	H	N-M	Weight	BLUCAST ref. no.
80	75-98mm	50	155	4-M12	10	BKF080050
100	97-118mm	50	165	4-M12	12,9	BKF100050
100	97-118mm	65	165	4-M12	13,4	BKF100065
100	97-118mm	80	170	4-M12	13,6	BKF100080
150	158-177mm	50	190	4-M16	15,6	BKF150050
150	158-177mm	80	200	4-M16	16,4	BKF150080
150	158-177mm	100	205	4-M16	16,7	BKF150100
200	206-233mm	50	225	6-M16	17	BKF150050
200	206-233mm	80	225	6-M16	17,4	BKF200080
200	206-233mm	100	230	6-M16	17,7	BKF200100
200	206-233mm	150	245	6-M16	18,3	BKF200150
250	260-286mm	100	270	6-M16	18,6	BKF250100
250	260-286mm	150	280	6-M16	19,4	BKF250150
300	313-338mm	100	300	8-M16	22,2	BKF300100
300	313-338mm	150	310	8-M16	24,8	BKF300150
400	400-435mm	100	405	4-M16	24,4	BKF400100
400	400-435mm	150	405	6-M16	27,1	BKF400150
500	506-535mm	100	455	4-M16	25,6	BKF500100
500	506-535mm	150	455	6-M16	30,1	BKF500150
600	610-640mm	100	505	4-M16	26,9	BKF600100
600	610-640mm	150	505	6-M16	35,8	BKF600150

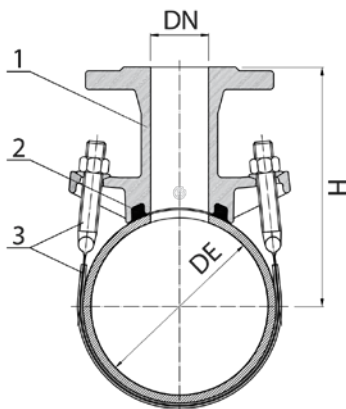

No.	Item	Material
1	Body	Ductile iron EN-GJS-500-7
2	Gasket	EPDM
3	Band, nuts	Stainless steel AISI304

All illustrations, technical data, dimensions (in mm) and weights (all weights specified in kg) are non-binding and are subject to change



SADDLE FOR PE/PVC PIPES series BPE



APPLICATION

BLUCAST saddles for PE/PVC are easy to mount, maintenance free and designed for long life.

TECHNICAL CHARACTERISTICS

Maximum working pressure: PN16 / 16 bar

Working temperature: 0°C - +70°C

Color RAL5015

Powder epoxy coating 250 µm thickness

TAPPING SADDLES

DN	DE	G	Length	H	Weight	BLUCAST ref. no.
DN50	50	1"	100	84	0.8	BPE0501
DN50	50	1 1/4"	100	84	0.8	BPE050114
DN50	50	1 1/2"	100	84	0.8	BPE050112
DN63	63	1"	100	97	1.2	BPE0631
DN63	63	1 1/4"	100	97	1.2	BPE063114
DN63	63	1 1/2"	100	97	1.2	BPE063112
DN63	63	2"	100	97	1.2	BPE0632
DN75	75	1"	100	111	1.35	BPE0751
DN75	75	1 1/4"	100	111	1.35	BPE075114
DN75	75	1 1/2"	100	111	1.35	BPE075112
DN75	75	2"	100	111	1.35	BPE0752
DN90	90	1"	100	124	1.7	BPE0901
DN90	90	1 1/4"	100	124	1.7	BPE090114
DN90	90	1 1/2"	100	124	1.7	BPE090112
DN90	90	2"	100	124	1.7	BPE0902
DN110	110	1"	110	148	2.3	BPE1101
DN110	110	1 1/4"	110	148	2.3	BPE110114
DN110	110	1 1/2"	110	148	2.3	BPE110112
DN110	110	2"	110	148	2.3	BPE1102
DN160	160	1"	125	209	5	BPE1601
DN160	160	1 1/4"	125	209	5	BPE160114
DN160	160	1 1/2"	125	209	5	BPE160112
DN160	160	2"	125	209	5	BPE1602
DN200	200	1"	125	251	6.4	BPE2001
DN200	200	1 1/4"	125	251	6.4	BPE200114
DN200	200	1 1/2"	125	251	6.4	BPE200112
DN200	200	2"	125	251	6.4	BPE2002
DN250	250	2"	168	351	13	BPE2502
DN315	315	2"	195	385	17.5	BPE3152

No.	Item	Material
1	Body	Ductile iron EN-GJS-500-7
2	Gasket	EPDM
3	Bolts	AISI304 stainless steel

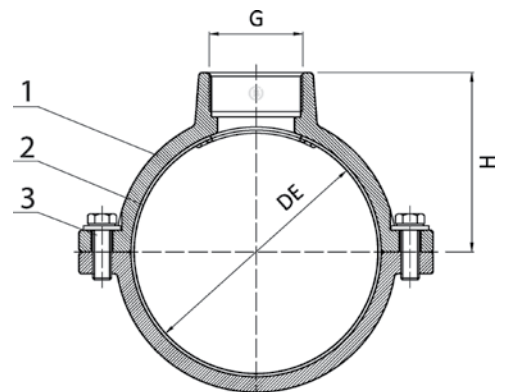

FLANGED SADDLE FOR PE/PVC PIPES series BPF



APPLICATION

BLUCAST flanged saddles for PE/PVC are easy to mount, maintenance free and designed for long life.

TECHNICAL CHARACTERISTICS

Flange end connections according to EN1092-2: PN10&PN16

Maximum working pressure: PN16 / 16 bar

Working temperature: 0°C - +70°C

Stainless steel bolts

Color RAL5015

Powder epoxy coating at least 250 µm thickness



TAPPING SADDLES

DE	DN	L	H	D	PN	Weight	BLUCAST ref. no.
110	50	200	165	165	PN10/16	7.7	BPF110050
110	65	200	165	185	PN10/16	8.8	BPF110065
110	80	200	165	200	PN10/16	9.6	BPF110080
160	50	230	190	165	PN10/16	12.9	BPF160050
160	80	230	190	200	PN10/16	15.9	BPF160080
160	100	230	190	220	PN10/16	17	BPF160100
200	50	230	220	165	PN10/16	16.3	BPF200050
200	80	230	230	200	PN10/16	17.2	BPF200080
200	100	230	230	220	PN10/16	18.4	BPF200100
225	50	230	240	165	PN10/16	18.7	BPF225050
225	80	230	240	200	PN10/16	20.5	BPF225080
225	100	230	240	220	PN10/16	21.8	BPF225100
250	50	300	230	165	PN10/16	21.2	BPF250050
250	80	300	240	200	PN10/16	22.2	BPF250080
250	100	300	240	220	PN10/16	23.5	BPF250100
250	150	300	240	285	PN10/16	31.4	BPF250150
315	50	300	295	165	PN10/16	31	BPF315050
315	80	300	295	200	PN10/16	32.2	BPF315080
315	100	300	315	220	PN10/16	33.1	BPF315100
315	150	300	315	285	PN10/16	37.6	BPF315150
400	80	390	330	200	PN10/16	44.7	BPF400080
400	100	390	330	220	PN10/16	45.8	BPF400100
400	150	390	330	285	PN10/16	48.6	BPF400150

No.	Item	Material
1	Body	Ductile iron EN-GJS-500-7
2	Gasket	EPDM
3	Bolts	AISI304 stainless steel

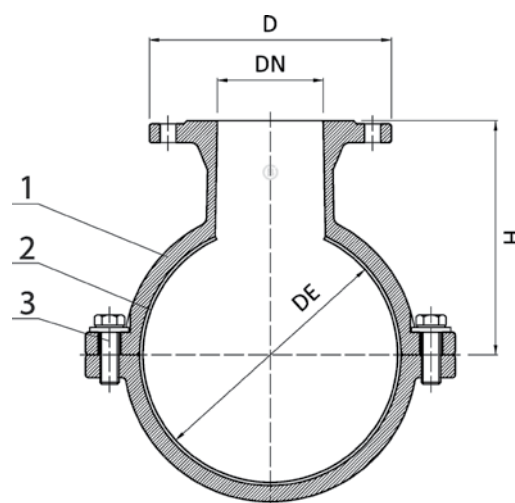

All illustrations, technical data, dimensions (in mm) and weights (all weights specified in kg) are non-binding and are subject to change



SADDLE FOR DUCTILE IRON PIPES series BK

STAINLESS STEEL BAND series JB



APPLICATION

BLUCAST series BK saddles can be used with different pipe sizes.
Designed to be used with series JB stainless steel bands.

TECHNICAL CHARACTERISTICS

Maximum working pressure: PN16 / 16 bar
Working temperature: 0°C - +70°C
Color RAL5015
Powder epoxy coating 250 µm thickness
Body from ductile iron EN-GJS-500-7
Gasket: EPDM

APPLICATION

JB stainless steel bands are to be used with BK saddles or BFL saddles.

TECHNICAL CHARACTERISTICS

Maximum working pressure: PN16 / 16 bar
Working temperature: 0°C - +70°C
Body from stainless steel AISI304
EPDM gasket

TAPPING SADDLES

DN	G	H	L	Weight	D1	Straps needed	BLUCAST ref. no.
50-200	1"	45	150	1.1	70	1	BK0501
50-200	1 1/4"	45	150	1.1	70	1	BK050114
50-200	1 1/2"	45	150	1.1	70	1	BK050112
100-300	1"	45	195	2.7	92	1	BK1001
100-300	1 1/4"	45	195	2.7	92	1	BK100114
100-300	1 1/2"	45	195	2.7	92	1	BK100112
100-300	2"	45	195	2.7	92	1	BK1002
80-700	2"	65	216	2.7	157	1	BK0802

DE range	BK 50-200	BK100-300	BK80-700	L	Weight	BLUCAST ref. no.
60-77	x			160	0.32	JB060077
77-95	x		x	200	0.34	JB077095
98-119	x		x	270	0.39	JB098119
102-122	x	x	x	278	0.40	JB102122
120-150	x	x	x	295	0.42	JB120150
125-135	x	x	x	295	0.43	JB125135
139-160	x	x	x	368	0.47	JB139160
150-180	x	x	x	392	0.49	JB150180
200-230		x	x	530	0.56	JB200230
230-250		x	x	610	0.60	JB230250
250-280		x	x	675	0.65	JB250280
285-315		x	x	770	0.71	JB285315
315-340		x	x	860	0.77	JB315340
410-435			x	1060	0.92	JB410435

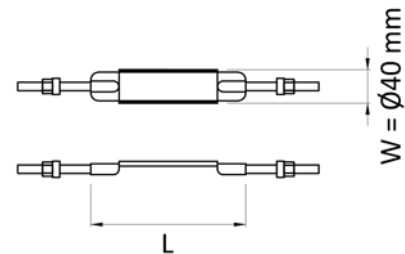
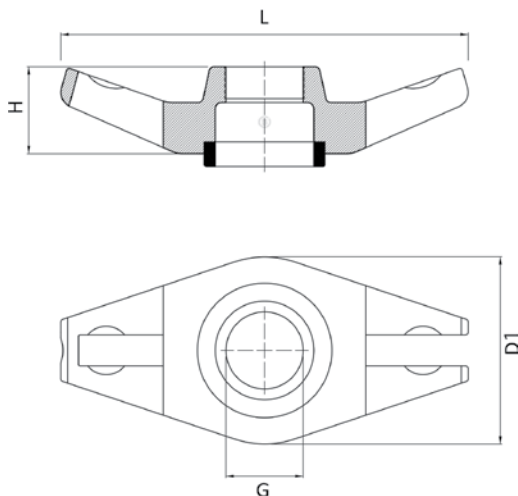

REPAIR CLAMP series RM



APPLICATION

Single and double band repair clamps used for repairing broken or leaking ductile iron, steel, PE or PVC water or sewage pipelines

TECHNICAL CHARACTERISTICS

Maximum working pressure: PN16 / 16 bar
 Working temperature: 0°C - +70°C
 Color RAL5015
 Powder epoxy coating 250 µm thickness



OTHER PRODUCTS

DEmin	DEmax	Lenght	Weight	PN	BLUCAST ref. no.
60	67	200	4.2	PN16	RM060200
75	85	200	4.3	PN16	RM075200
75	85	300	6	PN16	RM075300
88	98	200	4.4	PN16	RM088200
88	98	300	6.2	PN16	RM088300
108	118	200	4.7	PN16	RM108200
108	118	300	6.5	PN16	RM108300
115	128	200	4.6	PN16	RM115200
115	128	300	6.9	PN16	RM115300
132	144	200	4.7	PN16	RM132200
132	144	300	7.1	PN16	RM132300
151	161	200	4.8	PN16	RM151200
151	161	300	7.2	PN16	RM151300
158	172	200	4.9	PN16	RM158200
158	172	300	6.9	PN16	RM158300
168	182	200	4.9	PN16	RM168200
168	182	300	7.4	PN16	RM168300
193	203	200	5	PN16	RM193200
193	203	300	7.5	PN16	RM193300
217	229	200	5.5	PN16	RM217200
217	229	300	7.8	PN16	RM217300
243	260	200	5.8	PN16	RM243200
243	260	300	8.6	PN16	RM243300
270	288	200	5.9	PN16	RM270200
270	288	300	8.1	PN16	RM270300
304	323	200	6	PN16	RM304200
304	323	300	8.1	PN16	RM304300
323	336	200	6.2	PN16	RM323200
323	336	300	9.3	PN16	RM323300
410	432	300	15.2	PN16	RMD410300
410	432	400	21	PN16	RMD410400
510	540	400	21.7	PN16	RMD510400
630	660	500	36.6	PN16	RMD630500

No.	Item	Material
1	Head	Ductile iron EN-GJS-500-7
2	Body	Stainless steel AISI304
3	Gasket	EPDM
4	Bolts	Carbon steel zinc plated
5	Bolt caps	PE

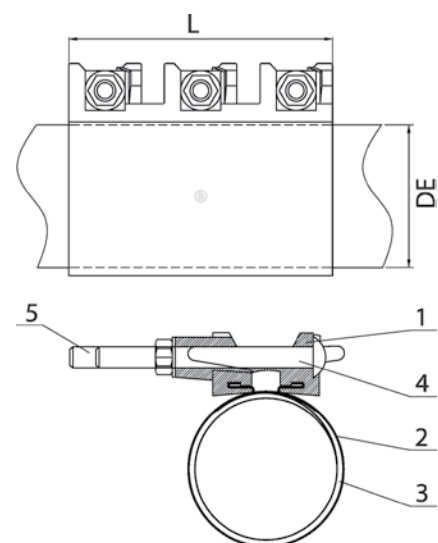

STAINLESS STEEL REPAIR CLAMP series RMSS



APPLICATION

Single clamp repair clamps used for repairing broken or leaking ductile iron, steel, PE or PVC water or sewage pipelines

TECHNICAL CHARACTERISTICS

Maximum working pressure: PN16 / 16 bar

Working temperature: 0°C - +70°C

Bolt nuts coated in nylon to prevent corrosion

OTHER PRODUCTS

DEmin	DEmax	Lenght	Weight	PN	BLUCAST ref. no.
60	67	200	1.5	PN16	RMSS060200
75	85	200	2	PN16	RMSS075200
88	98	200	2	PN16	RMSS088200
108	118	200	2.2	PN16	RMSS108200
108	118	300	3.3	PN16	RMSS108300
115	128	200	2.3	PN16	RMSS115200
115	128	300	3.4	PN16	RMSS115300
132	142	200	2.4	PN16	RMSS132200
132	142	300	3.6	PN16	RMSS132300
151	161	200	2.5	PN16	RMSS151200
151	161	300	3.7	PN16	RMSS151300
158	172	200	2.6	PN16	RMSS158200
158	172	300	3.8	PN16	RMSS158300
168	182	200	2.7	PN16	RMSS168200
168	182	300	4.1	PN16	RMSS168300
217	229	200	3.2	PN16	RMSS217200
217	229	300	4.7	PN16	RMSS217300
270	288	200	3.5	PN16	RMSS270200
270	288	300	5.3	PN16	RMSS270300
304	320	200	3.7	PN16	RMSS304200
304	320	300	5.6	PN16	RMSS304300
323	336	200	3.9	PN16	RMSS323200
323	336	300	5.8	PN16	RMSS323300

No.	Item	Material
1	Head	Stainless steel AISI304
2	Body	Stainless steel AISI304
3	Gasket	EPDM
4	Bolts	Stainless steel AISI304
5	Bolt caps	PE

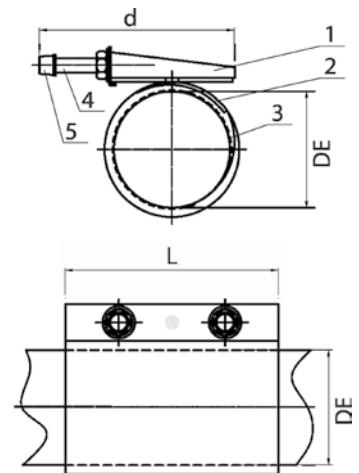

SPINDLE EXTENSIONS series TV, FV



TECHNICAL CHARACTERISTICS

Stem from zinc coated steel
 HDPE plastic cover
 Top and bottom caps are powder epoxy coated with 250 µm thickness

STREET BOX



TECHNICAL CHARACTERISTICS

Body from ductile iron EN-GJL-200
 Anticorrosion painting
 Zinc coated bolt holds the cover in place (4050 version)



OTHER PRODUCTS

DN	SQ	Lmin	Lmax	BLUCAST ref. no.
20-32	12	1300	1800	TV1318SQ12
20-50	14	1300	1800	TV1318SQ14
65-80	17	1300	1800	TV1318SQ17
100-150	19	1300	1800	TV1318SQ19
200	24	1300	1800	TV1318SQ24
250-400	27	1300	1800	TV1318SQ27
500-600	32	1300	1800	TV1318SQ32
20-32	12	2000	2500	TV2025SQ12
20-50	14	2000	2500	TV2025SQ14
65-80	17	2000	2500	TV2025SQ17
100-150	19	2000	2500	TV2025SQ19
200	24	2000	2500	TV2025SQ24
250-400	27	2000	2500	TV2025SQ27
500-600	32	2000	2500	TV2025SQ32
25-600	12-32	600	600	FV06SQ/...
25-600	12-32	1000	1000	FV10SQ/...
25-600	12-32	1500	1500	FV15SQ/...
25-600	12-32	2000	2000	FV20SQ/...

*custom lengths available by request

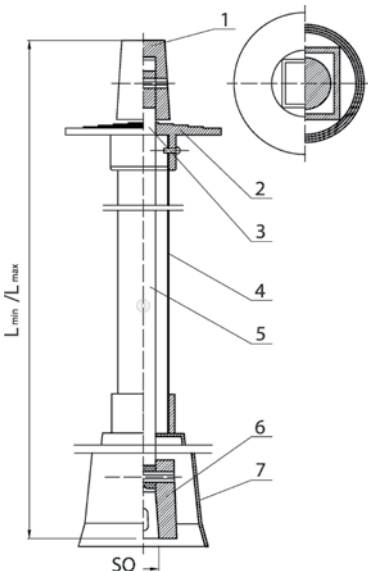

No.	Item	Material
1	Top cap	EN-GJL-250
2	Flange	HDPE
3	Connector	Galvanized steel
4	Cover	HDPE
5	Telescopic spindle	Galvanized steel
6	Bottom cap	EN-GJL-250
7	Bell	HDPE

	L	d	weight	BLUCAST ref. no.
small	150	110	2.9	4050
big	270	185	11	4056

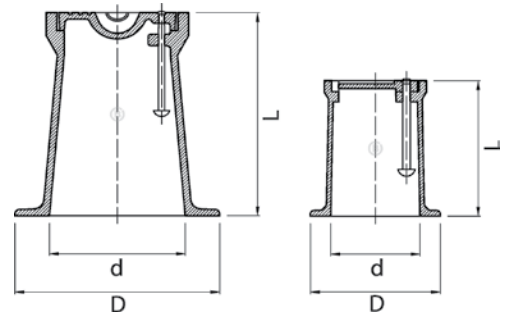

All illustrations, technical data, dimensions (in mm) and weights (all weights specified in kg) are non-binding and are subject to change



CERTIFICATES





CERTIFICATES

euofins Laboratoire habilité par le Ministère chargé de la santé en application de l'article N° 1221-02 du code de la santé publique

ATTESTATION DE CONFORMITE SANITAIRE
Certificate of sanitary conformity

Conformément à l'arrêté du 29 mai 1967 modifié et à la circulaire du Ministère de la Santé
Direction Générale de la Santé DGS/SDS/N° 571 du 25 Novembre 2002

Coordonnées du demandeur d'ACS / Contact details of the ACS owner :
BLUCAST UAB
Žirmūnų str. 68
LT-09131 Vilnius
Lituanie

Nom de l'accessoire représentatif / Reference of the representative accessory :
Vanne papillon - DEBV - DN40

N° de dossier attribué par le laboratoire habilité / File reference : 23 ACC NY 553

Date de réalisation des essais d'inerte selon la norme XP P41-200 / Tests date (according to the standard XP P 41-200) : Aucun essai n'est nécessaire à l'émission de cette ACS / No testing is required to issue this ACS

Commentaires / Comments : Les composants métalliques sont conformes à l'arrêté du 29 juin 2003 / Metallic components are compliant with the decree dated 29th June 2003

Famille d'accessoires couverts par l'ACS / Accessories' family covered by this certificate :
VANNES PAPILLON - DEBV

Références / References (1 article et ses variantes) :
DEBV - de DN40 à DN1000

Attestation délivrée par / Certificate issued by :
Lisa Filizianas
Coordonnatrice de projets clients / Analytical Service Manager
Date de délivrance / Date of issue : 28 novembre 2023
Date d'expiration / Expiry date : 25 mai 2028
Commentaires / Comments : /

Signature:

Reference: T-AM-PC02002

euofins Laboratoire habilité par le Ministère chargé de la santé en application de l'article N° 1221-02 du code de la santé publique

ATTESTATION DE CONFORMITE SANITAIRE
Certificate of sanitary conformity

Conformément à l'arrêté du 29 mai 1967 modifié et à la circulaire du Ministère de la Santé
Direction Générale de la Santé DGS/SDS/N° 571 du 25 Novembre 2002

Coordonnées du demandeur d'ACS / Contact details of the ACS owner :
BLUCAST UAB
Žirmūnų str. 68
LT-09131 Vilnius
Lituanie

Nom de l'accessoire représentatif / Reference of the representative accessory :
Cajet en fonte anti-retour à boule - ARV - DR50

N° de dossier attribué par le laboratoire habilité / File reference : 23 ACC NY 552

Date de réalisation des essais d'inerte selon la norme XP P41-200 / Tests date (according to the standard XP P 41-200) : Aucun essai n'est nécessaire à l'émission de cette ACS / No testing is required to issue this ACS

Famille d'accessoires couverts par l'ACS / Accessories' family covered by this certificate :
CLAPETS EN FONTE ANTI-RETOUR A BOULE - ARV

Références / References (1 article et ses variantes) :
ARV - de DN50 à DN100

Attestation délivrée par / Certificate issued by :
Lisa Filizianas
Coordonnatrice de projets clients / Analytical Service Manager
Date de délivrance / Date of issue : 28 novembre 2023
Date d'expiration / Expiry date : 25 mai 2028
Commentaires / Comments : /

Signature:

Reference: T-AM-PC02001

CARSO - LABORATOIRE SANTÉ ENVIRONNEMENT HYGIÈNE DE LYON
Laboratoire Agréé pour les analyses d'eau par le Ministère de la Santé

Laboratoire habilité par le Ministère chargé de la santé en application de l'article N° 1221-02 du code de la santé publique

ATTESTATION DE CONFORMITE SANITAIRE
Certificate of sanitary conformity

Conformément à l'arrêté du 29 mai 1967 modifié et à la circulaire du Ministère de la Santé
Direction Générale de la Santé DGS/SDS/N° 571 du 25 Novembre 2002

Coordonnées du demandeur d'ACS / Contact details of the ACS owner :
BLUCAST
Žirmūnų str. 68
09131 VILNIUS
Lituanie

Nom de l'accessoire représentatif / Reference of the representative accessory :
Robinet vanne à opercule / Resilient gate valve ZN68

N° de dossier attribué par le laboratoire habilité / File reference : 20 ACC LY 586

Date de réalisation des essais d'inerte selon la norme XP P41-200 / Tests date (according to the standard XP P 41-200) : aucun essai de migration n'est nécessaire / No testing is required to issue this ACS

Commentaires / Comments : ACS basée sur l'ACS 20 ACC LY 294 avec accord écrit du client / ACS based on the ACS 20 ACC LY 294 with the written agreement of the client

Famille d'accessoires couverts par l'ACS / Accessories' family covered by this certificate :
Robinet vanne à opercule / Resilient gate valve

Références / Reference (1 référence) :
DN40 - DN1000

Attestation délivrée par / Certificate issued by :
Christine AUFUSSELLE
Responsable MCOE
CARSO - L.S.E.M.L.
Date de délivrance / Date of issue : 22 Octobre 2020
Date d'expiration / Expiry date : 23 Juin 2025
Commentaires / Comments : renouvellement / renewal 18 ACC LY 292

Signature:

Reference: T-AM-PC02002

NACIOWY INSTYTUT ZDROWIA PUBLICZNEGO - Państwowy Zakład Higieny
NATIONAL INSTITUTE OF PUBLIC HEALTH - National Institute of Hygiene

ZAKŁAD BEZPIECZEŃSTWA ŻYWIENIA I ŚRODOWISKA
DEPARTMENT OF ENVIRONMENTAL HEALTH AND SAFETY

ATEST HIGIENICZNY B-BK-40210-0722/21
HYGIENIC CERTIFICATE ORIGINAL

NATIONAL INSTITUTE OF PUBLIC HEALTH - NATIONAL INSTITUTE OF HYGIENE

Wyrob / product: Zasuwy ballone, kształtów kulistowate, adaptery, kłoda

Zawieszenia / coating: żelazo szlachczone, powłoka epoksydowa, EPDM

Przeznaczony do / destined: instalacji w instalacjach służących do przesyłania wody przystrojonej do recyklingu przez ludzi przez rozdzielny urządzenie

Wymagany wobec produktu odpowiada wymogom higienicznym przy spełnieniu następujących warunków / The above-named product is acceptable according to hygienic criteria with the following conditions: technologia instalacji do przesyłania wody przystrojonej do recyklingu przez ludzi; przed oddaniem do użytku należy przeprowadzić wstępny wypróbowanie jej całkowity system / ACS nie dotyczy parametrów technicznych wyrobów / hygienic certificate does not apply to technical parameters of the products.

Wytwórca / producer: BLUCAST JSC
LT-09131 Vilnius
Žirmūnų str. 68, Litva

Należy dokument wytwórca nie wpisuje / the certificate issued for: BLUCAST JSC
LT-09131 Vilnius
Žirmūnų str. 68, Litva

Atest może być anulowany lub unieważniony po przedstawieniu odpowiednich dowodów przez zainteresowaną stronę. Należy zgłosić zmianę po 2024.06.17 lub w przypadku zmian w recepturze albo w technologii wytworzenia wyrobu. / The certificate may be cancelled or annulled after appropriate notification. The certificate loses its validity after 2024.06.17 or in the case of changes in composition or in technology of production.

Data wydania atestu higienicznego: 17 czerwca 2021
The date of issue of the certificate: 17th June 2021

Podpis:

Podpis:

Instytut w sprawie bezpieczeństwa żywności i środowiska / In contact regarding the hygiene certificate
Zakład Bezpieczeństwa Żywności i Środowiska (NZP-ZNS) Department of Environmental Health and Safety (NZP-ZNS)
02-507 Warszawa, ul. Chałubińskiego 54 / 00-271 Warsaw, Chałubińskiego 54, Poland
e-mail: atest@instytut.gov.pl tel: +48 22 54 21 364, +48 22 54 21 340





Žirmūnų g. 66, LT-09131 Vilnius, Lithuania
Tel. +370 5 273 5865, +370 5 273 5866, e-mail: info@blucast.eu

www.blucast.eu