

SINGLE BALL FLANGED AIR VALVE series NVF



VALVES



APPLICATION

Single ball air valve for drinking water and neutral liquids up to 80°C

DESIGN FEATURES

The air release component releases entrapped air in pressurized systems
 Single orifice, single function
 Universal flange DN40/50/65, PN10/16
 Simple and reliable structure, small dimensions, lightweight

TECHNICAL CHARACTERISTICS

Hydrostatic tests according EN-12266-1, class A
 Designed to EN-1074/4 and AWWA C-512
 Color RAL5015
 Powder epoxy coating 250 µm thickness

DN	Air valve	Weight	BLUCAST ref. no.
50	1"	7.5	NVF0501

No.	Item	Material
1	Flange	Ductile iron
2	Ball valve 1"	Brass
3	Body	Ductile iron
4	Float	ABS
5	Seat	EPDM
6	Hinge Pin	Stainless steel AISI304
7	O ring	NBR
8	Bonnet	Ductile iron
9	Bracket	Brass
10	O ring	NBR
11	O ring	NBR
12	Cap	Brass
13	Bolt	AISI304 stainless steel
14	Washer	AISI304 stainless steel

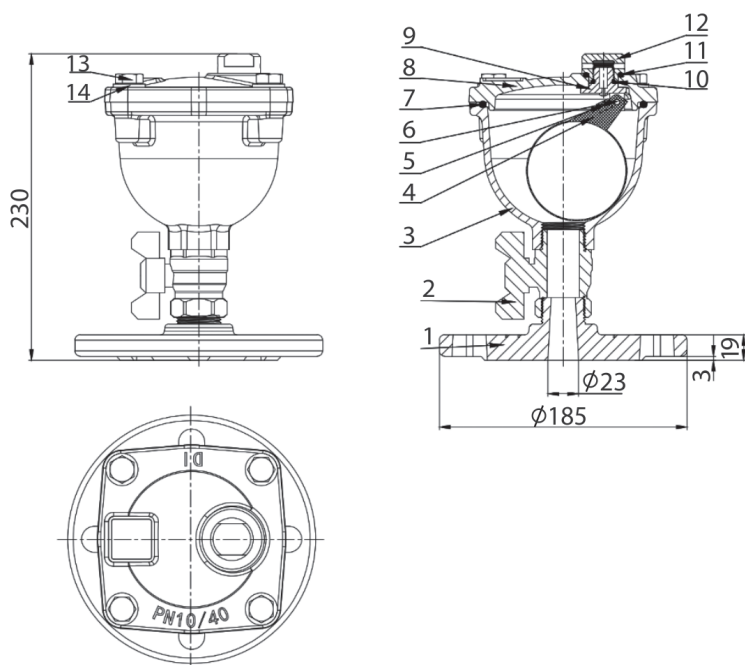

All illustrations, technical data, dimensions (in mm) and weights (all weights specified in kg) are non-binding and are subject to change

