

FLANGED SADDLE FOR PE/PVC PIPES series BPF



APPLICATION

BLUCAST flanged saddles for PE/PVC are easy to mount, maintenance free and designed for long life.

TECHNICAL CHARACTERISTICS

Flange end connections according to EN1092-2: PN10&PN16
 Maximum working pressure: PN16 / 16 bar
 Working temperature: 0°C - +70°C
 Stainless steel bolts
 Color RAL5015
 Powder epoxy coating at least 250 µm thickness



TAPPING SADDLES

DE	DN	L	H	D	PN	Weight	BLUCAST ref. no.
110	50	200	165	165	PN10/16	7.7	BPF110050
110	65	200	165	185	PN10/16	8.8	BPF110065
110	80	200	165	200	PN10/16	9.6	BPF110080
160	50	230	190	165	PN10/16	12.9	BPF160050
160	80	230	190	200	PN10/16	15.9	BPF160080
160	100	230	190	220	PN10/16	17	BPF160100
200	50	230	220	165	PN10/16	16.3	BPF200050
200	80	230	230	200	PN10/16	17.2	BPF200080
200	100	230	230	220	PN10/16	18.4	BPF200100
225	50	230	240	165	PN10/16	18.7	BPF225050
225	80	230	240	200	PN10/16	20.5	BPF225080
225	100	230	240	220	PN10/16	21.8	BPF225100
250	50	300	230	165	PN10/16	21.2	BPF250050
250	80	300	240	200	PN10/16	22.2	BPF250080
250	100	300	240	220	PN10/16	23.5	BPF250100
250	150	300	240	285	PN10/16	31.4	BPF250150
315	50	300	295	165	PN10/16	31	BPF315050
315	80	300	295	200	PN10/16	32.2	BPF315080
315	100	300	315	220	PN10/16	33.1	BPF315100
315	150	300	315	285	PN10/16	37.6	BPF315150
400	80	390	330	200	PN10/16	44.7	BPF400080
400	100	390	330	220	PN10/16	45.8	BPF400100
400	150	390	330	285	PN10/16	48.6	BPF400150

No.	Item	Material
1	Body	Ductile iron EN-GJS-500-7
2	Gasket	EPDM
3	Bolts	AISI304 stainless steel

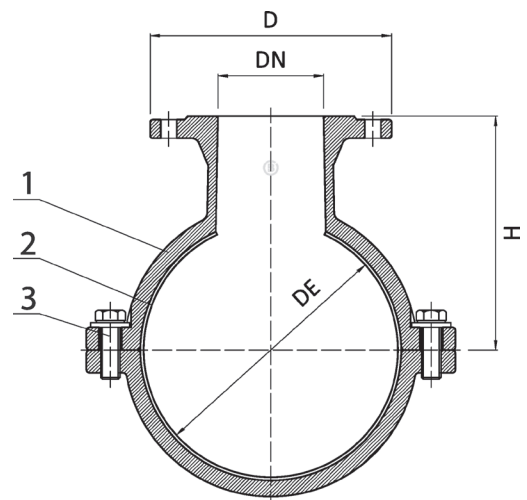

All illustrations, technical data, dimensions (in mm) and weights (all weights specified in kg) are non-binding and are subject to change

