

FLANGED SADDLE WITH SS BAND FOR DI PIPES series BKF



APPLICATION

BLUCAST saddles for ductile iron pipes are easy to mount, maintenance free and designed for long life.

TECHNICAL CHARACTERISTICS

Flange end connections according to EN1092-2: PN10/PN16

Designed according to EN545

Maximum working pressure: PN16 / 16 bar

Working temperature: 0°C - +70°C

Color RAL5015

Powder epoxy coating 250 µm thickness

Body from ductile iron EN-GJS-500-7



TAPPING SADDLES

DN	DE range	Outlet DN	H	N-M	Weight	BLUCAST ref. no.
80	75-98mm	50	155	4-M12	10	BKF080050
100	97-118mm	50	165	4-M12	12,9	BKF100050
100	97-118mm	65	165	4-M12	13,4	BKF100065
100	97-118mm	80	170	4-M12	13,6	BKF100080
150	158-177mm	50	190	4-M16	15,6	BKF150050
150	158-177mm	80	200	4-M16	16,4	BKF150080
150	158-177mm	100	205	4-M16	16,7	BKF150100
200	206-233mm	50	225	6-M16	17	BKF150050
200	206-233mm	80	225	6-M16	17,4	BKF200080
200	206-233mm	100	230	6-M16	17,7	BKF200100
200	206-233mm	150	245	6-M16	18,3	BKF200150
250	260-286mm	100	270	6-M16	18,6	BKF250100
250	260-286mm	150	280	6-M16	19,4	BKF250150
300	313-338mm	100	300	8-M16	22,2	BKF300100
300	313-338mm	150	310	8-M16	24,8	BKF300150
400	400-435mm	100	405	4-M16	24,4	BKF400100
400	400-435mm	150	405	6-M16	27,1	BKF400150
500	506-535mm	100	455	4-M16	25,6	BKF500100
500	506-535mm	150	455	6-M16	30,1	BKF500150
600	610-640mm	100	505	4-M16	26,9	BKF600100
600	610-640mm	150	505	6-M16	35,8	BKF600150

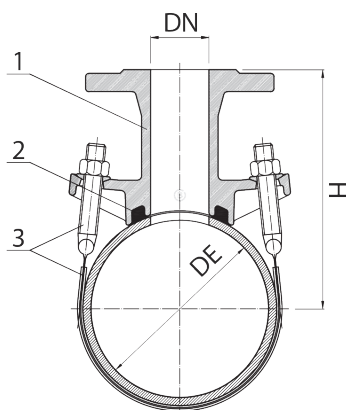

No.	Item	Material
1	Body	Ductile iron EN-GJS-500-7
2	Gasket	EPDM
3	Band, nuts	Stainless steel AISI304

All illustrations, technical data, dimensions (in mm) and weights (all weights specified in kg) are non-binding and are subject to change

