

# UNIMAX UNIVERSAL ADAPTOR series AUN



## APPLICATION

Universal flange adaptor is used for connecting various pipe materials with flanged fittings

## DESIGN FEATURES

Large tolerance  
Universal drilling for compatibility with both PN10 and PN16  
The bolt ends are protected with plastic caps

## TECHNICAL CHARACTERISTICS

Flange end connections according to EN1092-2: PN10/PN16  
Maximum working pressure: PN16 / 16 bar  
Working temperature: 0°C - +70°C  
Color RAL5015  
Powder epoxy coating 250 µm thickness  
Bolts, nuts and washers - carbon steel 8.8 hot dip galvanized  
Maximum angular deflection - 4°

# UNIMAX UNIVERSAL COUPLING series MUN



## APPLICATION

Universal couplings are used for connecting various pipes

## DESIGN FEATURES

Large tolerance  
The bolt ends are protected with plastic caps

## TECHNICAL CHARACTERISTICS

Maximum working pressure: PN16 / 16 bar  
Working temperature: 0°C - +70°C  
Color RAL5015  
Powder epoxy coating 250 µm thickness  
Bolts, nuts and washers - carbon steel 8.8 hot dip galvanized  
Maximum angular deflection at each end - 4°



FLANGE ADAPTORS AND COUPLINGS

DN	DE	D	H	Bolts	Bolt qty.	KG	BLUCAST ref. no.
50	57-74	164	75	M12x120	4	3	AUN050
65	63-85	182	75	M12x120	4	3.8	AUN065
80	85-107	192	75	M12x120	4	4	AUN080
100	107-132	224	75	M12x120	4	5	AUN100
125	132-158	246	75	M12x120	4	6.2	AUN125
150	158-184	283	75	M12x120	4	6.5	AUN150
175	189-212	333	75	M12x140	4	8.4	AUN175
200	200-225	333	75	M12x140	4	10.2	AUN200225
200	218-244	333	75	M12x140	4	8.4	AUN200
225	243-269	375	85	M12x140	6	11.3	AUN225
250	266-295	394	85	M12x140	6	11.4	AUN250
300	315-349	440	85	M12x140	6	14.6	AUN300
350	351-378	481	111	M14x180	8	29	AUN350
400	400-420	526	111	M14x180	8	31.2	AUN400420
400	417-437	536	111	M14x180	8	32.5	AUN400
500	500-532	715	113	M16x180	10	51	AUN500532
500	526-546	618	113	M14x180	10	47	AUN500
600	630-650	734	115	M14x180	10	63	AUN600

No.	Item	Material
1	Bracket	Ductile iron EN-GJS-500-7
2	Body	Ductile iron EN-GJS-500-7
3	Bolt	8.8 carbon steel hot dip galvanized
4	Sealing gasket	EPDM

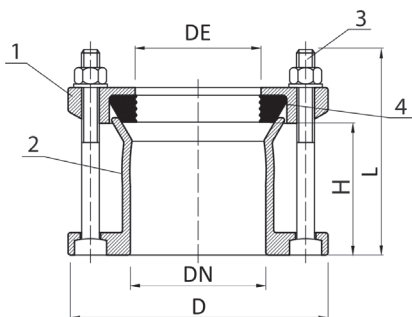

DN	DE	D	H	Bolts	Bolt qty.	KG	BLUCAST ref. no.
50	57-74	164	100	M12x180	2	3.2	MUN050
65	63-85	182	100	M12x180	2	3.7	MUN065
80	85-107	192	100	M12x180	4	4.3	MUN080
100	107-132	224	100	M12x180	4	5.3	MUN100
125	132-158	246	110	M12x190	4	6.4	MUN125
150	158-184	283	110	M12x190	4	7.2	MUN150
175	192-210	304	110	M12x190	4	9	MUN175
200	200-225	333	130	M12x210	4	9.7	MUN200225
200	218-244	333	130	M12x210	4	10.3	MUN200
225	243-269	375	130	M12x210	4	12	MUN225
250	266-295	394	130	M12x220	6	13.7	MUN250
300	315-349	440	130	M12x220	6	17.8	MUN300
350	351-378	481	130	M14x250	8	27	MUN350
400	417-437	536	130	M14x250	8	28	MUN400
500	526-546	618	130	M14x250	10	38.5	MUN500
600	630-650	734	130	M14x250	10	59	MUN600

No.	Item	Material
1	Bracket	Steel
2	Body	Ductile iron EN-GJS-500-7
3	Bolt	8.8 carbon steel hot dip galvanized
4	Sealing gasket	EPDM

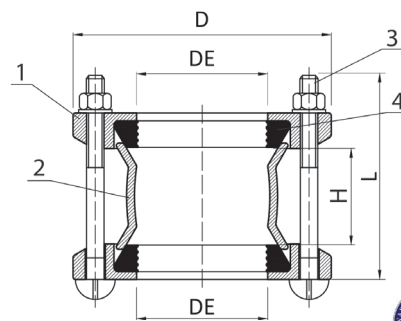

All illustrations, technical data, dimensions (in mm) and weights (all weights specified in kg) are non-binding and are subject to change

