

THREADED GATE VALVE PN16 series 015



GATE VALVES



APPLICATION

Threaded gate valve for drinking water and neutral liquids up to 80°C

DESIGN FEATURES

- Non rising stainless steel stem
- Thread connection according to PN-EN ISO 228-1
- Straight passage without slots
- Low closing torque
- 100% watertight, class A
- No zones of retention
- Clockwise closing

TECHNICAL CHARACTERISTICS

- Requirements and tests: according to PN-EN 1074-1.2
- Maximum working pressure: PN16 / 16 bar
- Working temperature: 0°C - +80°C
- Powder epoxy coating at least 250 µm thickness, UV resistant, Color RAL5015
- Sealing torque: DN20-DN32-15Nm, DN40-DN50-30Nm
- Spindle/ shaft seal: O-ring
- Maximum water speed: 4 m/s
- Version with both internal threads - code "VV".
- Version with internal/external threads - code "VI".

OPERATING



DN	Threads G	H	L	P	SQ	Kg	BLUCAST ref. no.
20	3/4" int/int	145	95	27	12	1.2	015VV020
25	1" int/int	145	105	30	12	1.5	015VV025
32	1 1/4" int/int	150	120	32	12	2	015VV032
40	1 1/2" int/int	197	130	37	14	3	015VV040
50	2" int/int	202	150	45	14	4	015VV050
25	1" int/ext	126	110	22	14	1.2	010VI025
32	1 1/4" int/ext	150	120	32	12	2	015VI032
40	1 1/2" int/ext	182	112	22	14	2.6	010VI040
50	2" int/ext	200	130	26	14	3.2	010VI050

No.	Item	Material
1	Body	EN GJS-500-7
2	Wedge	DN20-DN32 EN Brass/EPDM, DN40-DN50 - EN GJS-500-7/EPDM
3	Bonnet gasket	EPDM
4	Stem	A2 stainless steel
5	Bonnet	EN GJS-500-7
6	Thrust washer	Brass
7	Thrust	Brass
8	Thrust nut	Brass
9	O ring	EPDM
10	O ring	EPDM
11	O ring	EPDM
12	O ring	EPDM
13	Bolts	A2 stainless steel
14	Stem nut	Brass

DN20/DN25/DN32

DN40/DN50

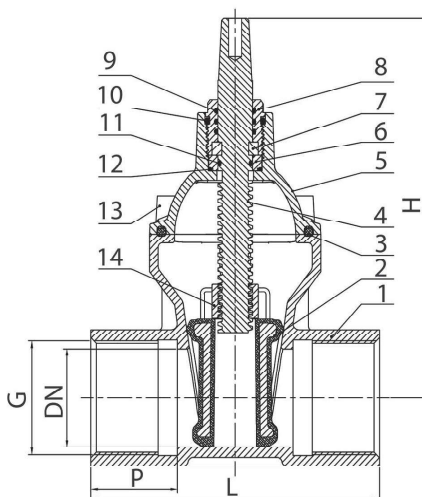
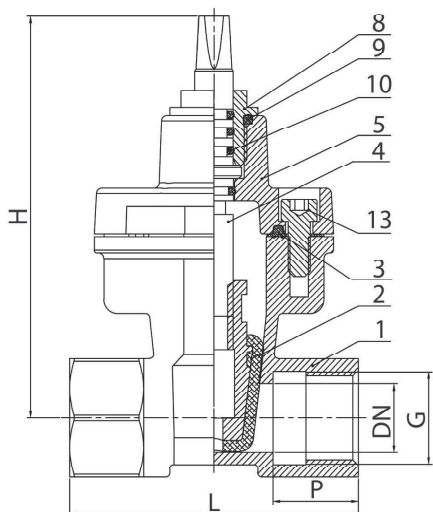

All illustrations, technical data, dimensions (in mm) and weights (all weights specified in kg) are non-binding and are subject to change