

# DISMANTLING JOINT series DJ



## TECHNICAL CHARACTERISTICS

Flange end connections according to EN1092-2: PN10/PN16  
 Designed according to EN545  
 Maximum working pressure: PN16 / 16 bar  
 Working temperature: 0°C - +70°C  
 Color RAL5015  
 Powder epoxy coating 250 µm thickness  
 Body from ductile iron EN-GJS-500-7  
 Bolts, nuts and washers - hot dip galvanized 8.8 carbon steel  
 or stainless steel A2 option available  
 Gasket - EPDM. NBR option available



DUCTILE IRON FITTINGS

Nominal size	Flange drilling	D	L1 min	L1 max	Bolt	Quantity & hole size	Weight	BLUCAST ref. no.
DN50	PN10/16	165	170	220	M16	4 x 19	9.6	DJ050
DN65	PN10/16	185	170	220	M16	4 x 19	12.6	DJ065
DN80	PN10/16	200	190	240	M16	8 x 19	15.8	DJ080
DN100	PN10/16	220	200	250	M16	8 x 19	18	DJ100
DN125	PN10/16	250	200	250	M16	8 x 19	22	DJ125
DN150	PN10/16	285	200	250	M20	8 x 23	28.7	DJ150
DN200	PN10	340	200	250	M20	8 x 23	35.5	DJ200
DN200	PN16	340	200	250	M20	12 x 23	41.5	DJP200
DN250	PN10	400	210	260	M20	12 x 23	53.1	DJ250
DN250	PN16	400	210	260	M24	12 x 28	58.3	DJP250
DN300	PN10	455	220	270	M20	12 x 23	61.6	DJ300
DN300	PN16	455	220	270	M24	12 x 28	74.5	DJP300
DN350	PN10	505	230	280	M20	16 x 23	82.5	DJ350
DN400	PN10	565	240	290	M24	16 x 28	95	DJ400
DN500	PN10	670	260	310	M24	20 x 28	126.2	DJ500
DN600	PN10	780	280	330	M27	20 x 31	170	DJ600
DN700	PN10	895	290	340	M27	24 x 31	235	DJ700
DN800	PN10	1015	300	350	M30	24 x 34	248	DJ800
DN900	PN10	1115	310	360	M30	28 x 34	327	DJ900
DN1000	PN10	1230	315	365	M33	28 x 37	354	DJ1000
DN1200	PN10	1455	350	400	M36	32 x 40	507	DJ1200

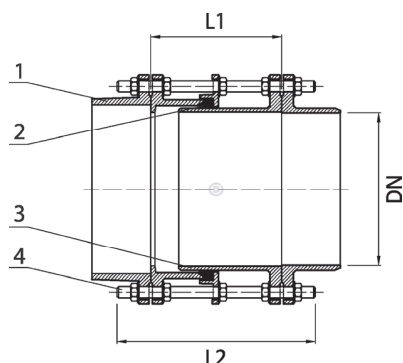

No.	Item	Material
1	Body	Ductile iron EN-GJS-500-7
2	Gasket	EPDM
3	Body	Ductile iron EN-GJS-500-7
4	Bolts	8.8 steel hot dip galvanized

All illustrations, technical data, dimensions (in mm) and weights (all weights specified in kg) are non-binding and are subject to change

