

ALL FLANGED TEE series T



TECHNICAL CHARACTERISTICS

Flange end connections according to EN1092-2: PN10/PN16

Designed according to EN545

Maximum working pressure: PN16 / 16 bar

Working temperature: 0°C - +70°C

Color RAL5015

Powder epoxy coating 250 µm thickness

Body from ductile iron EN-GJS-500-7

WRAS approved epoxy coating, ACS approved epoxy coating under request

DN1	DN2	Flange drilling	L	H	e1	e2	Weight	BLUCAST ref. no.	DN1	DN2	Flange drilling	L	H	e1	e2	Weight	BLUCAST ref. no.
50	50	PN10/16	300	150	7	7	9.8	T050050	250	150	PN10	485	280	9	7.8	62	T250150
65	50	PN10/16	330	165	7	7	12	T065050	250	150	PN16	485	280	9	7.8	62	TP250150
65	65	PN10/16	330	165	7	7	13	T065065	250	200	PN10	540	290	9	8.4	64.8	T250200
80	50	PN10/16	310	145	7	7	13	T080050	250	200	PN16	540	290	9	8.4	64.8	TP250200
80	65	PN10/16	330	160	7	7	13.5	T080065	250	250	PN10	600	300	9	9	89	T250250
80	80	PN10/16	330	165	7	7	11.9	T080080	250	250	PN16	600	300	9	9	89	TP250250
100	50	PN10/16	320	165	7.2	7	12.7	T100050	300	80	PN10	425	295	9.6	7	62	T300080
100	65	PN10/16	360	165	7.2	7	13.5	T100065	300	80	PN16	425	295	9.6	7	62	TP300080
100	80	PN10/16	330	170	7.2	7	15.4	T100080	300	100	PN10	450	300	9.6	7.2	65	T300100
100	100	PN10/16	360	180	7.2	7.2	15.3	T100100	300	100	PN16	450	300	9.6	7.2	65	TP300100
150	50	PN10/16	335	175	7.8	7	27.8	T150050	300	150	PN10	505	310	9.6	7.8	82	T300150
150	65	PN10/16	440	195	7.8	7	28	T150065	300	150	PN16	505	310	9.6	7.8	82	TP300150
150	80	PN10/16	360	200	7.8	7	28.5	T150080	300	200	PN10	565	320	9.6	8.4	85	T300200
150	100	PN10/16	440	210	7.8	7.2	29.5	T150100	300	200	PN16	565	320	9.6	8.4	85	TP300200
150	150	PN10/16	440	220	7.8	7.8	30.7	T150150	300	250	PN10	620	330	9.6	9	90	T300250
200	50	PN10	365	200	8.4	7	32	T200050	300	300	PN10	680	340	9.6	9.6	100.9	T300300
200	65	PN10	365	215	8.4	7	32.8	T200065	300	300	PN16	680	340	9.6	9.6	100.9	TP300300
200	80	PN10	380	225	8.4	7	30.9	T200080	400	80	PN10	470	355	10.8	7	91	T400080
200	100	PN10	400	230	8.4	7.2	35.5	T200100	400	100	PN10	490	360	10.8	7.2	91	T400100
200	100	PN16	400	230	8.4	7.2	35.5	TP200100	400	150	PN10	550	370	10.8	7.8	97.5	T400150
200	150	PN10	460	245	8.4	7.8	40.5	T200150	400	200	PN10	610	380	10.8	8.4	113.1	T400200
200	150	PN16	460	245	8.4	7.8	40.5	TP200150	400	250	PN10	665	390	10.8	9	125.1	T400250
200	200	PN10	520	260	8.4	8.4	45.4	T200200	400	300	PN10	725	400	10.8	9.6	138.4	T400300
200	200	PN16	520	260	8.4	8.4	45.4	TP200200	400	400	PN10	840	420	10.8	10.8	163.3	T400400
250	65	PN10	385	260	9	7	45	T250065	500	100	PN10	535	400	12	7.2	133.5	T500100
250	80	PN10	405	265	9	7	48	T250080	500	150	PN10	600	410	12	7.8	146.6	T500150
250	100	PN10	425	270	9	7.2	52.6	T250100	500	200	PN10	650	415	12	8.4	157.5	T500200
250	100	PN16	425	270	9	7.2	52.6	TP250100	500	300	PN10	740	450	12	9.6	150	T500300
									500	400	PN10	885	480	12	10.8	216.9	T500400
									500	500	PN10	1000	500	12	12	252	T500500
									600	100	PN10	550	450	13.2	7.2	180.4	T600100
									600	150	PN10	650	455	13.2	7.8	203.8	T600150
									600	200	PN10	700	460	13.2	8.4	211	T600200
									600	300	PN10	810	500	13.2	9.6	250.3	T600300
									600	400	PN10	930	530	13.2	10.8	285.8	T600400
									600	600	PN10	1100	550	13.2	13.2	355	T600600

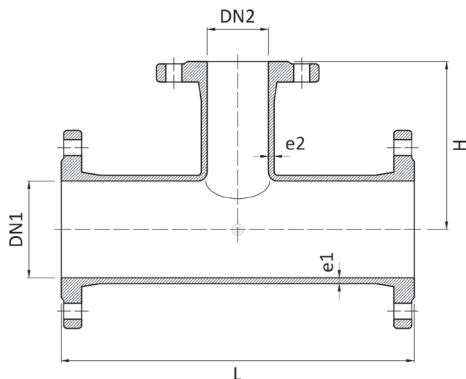

All illustrations, technical data, dimensions (in mm) and weights (all weights specified in kg) are non-binding and are subject to change

