

DOUBLE FLANGED BEND 90° series Q

DOUBLE FLANGED BEND 45° series FFK



DUCTILE IRON FITTINGS



TECHNICAL CHARACTERISTICS

Flange end connections according to EN1092-2: PN10 or PN16
 Designed according to EN545
 Maximum working pressure: PN16 / 16 bar
 Working temperature: 0°C - +70°C
 Color RAL5015
 Powder epoxy coating 250 µm thickness
 Body from ductile iron EN-GJS-500-7
 WRAS approved epoxy coating,
 ACS approved epoxy coating under request

TECHNICAL CHARACTERISTICS

Flange end connections according to EN1092-2: PN10/PN16
 Designed according to EN545
 Maximum working pressure: PN16 / 16 bar
 Working temperature: 0°C - +70°C
 Color RAL5015
 Powder epoxy coating 250 µm thickness
 Body from ductile iron EN-GJS-500-7
 WRAS approved epoxy coating,
 ACS approved epoxy coating under request

DN	Flange drilling	L	e	Weight	BLUCAST ref. no.
50	PN10/16	150	7	6.1	Q050
65	PN10/16	160	7	8.5	Q065
80	PN10/16	165	7	9.7	Q080
100	PN10/16	180	7.2	11.9	Q100
150	PN10/16	220	7.8	18.3	Q150
200	PN10	260	8.4	33.6	Q200
200	PN16	260	8.4	33.6	QP200
250	PN10	350	9	52	Q250
250	PN16	350	9	52	QP250
300	PN10	400	9.6	72	Q300
300	PN16	400	9.6	72	QP300
400	PN10	500	10.4	151	Q400
500	PN10	600	12	190	Q500
600	PN10	700	13.2	286	Q600

DN	Flange drilling	L	e	Weight	BLUCAST ref. no.
50	PN10/16	150	7	7.6	FFK050
65	PN10/16	165	7	8.7	FFK065
80	PN10/16	130	7	9.3	FFK080
100	PN10/16	140	7.2	10.8	FFK100
150	PN10/16	160	7.8	19	FFK150
200	PN10	180	8.4	28	FFK200
250	PN10	245	9	46	FFK250
300	PN10	275	9.6	64	FFK300
400	PN10	325	10.4	96	FFK400
500	PN10	375	12	145	FFK500
600	PN10	400	13.2	211	FFK600

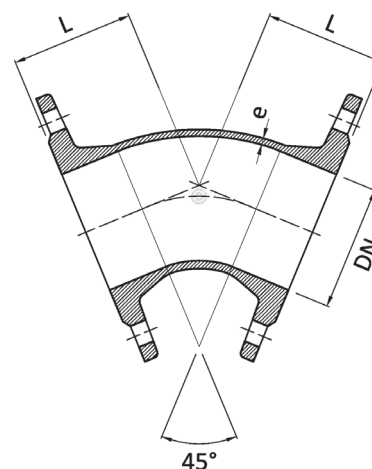
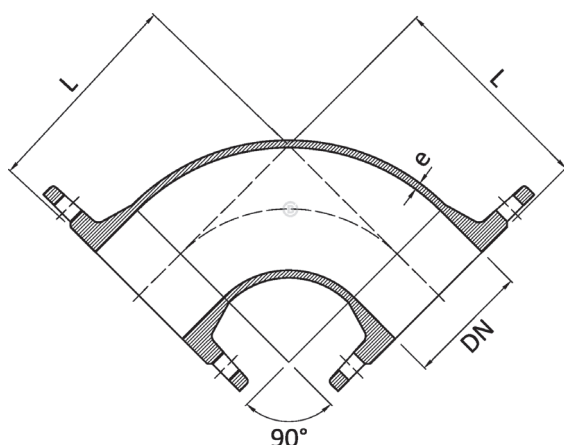

All illustrations, technical data, dimensions (in mm) and weights (all weights specified in kg) are non-binding and are subject to change

