

# DOUBLE BALL AIR VALVE series NVD



GATE VALVES



## APPLICATION

Air valve for drinking water and neutral liquids up to 80°C

## DESIGN FEATURES

The air release component releases entrapped air in pressurized systems  
Air & vacuum component admits large volumes of air during drainage and at water column separation  
Dynamic design allows for high velocity air discharge while preventing premature closure  
Simple and reliable structure, small dimensions, lightweight

## TECHNICAL CHARACTERISTICS

Design according to EN1074-4  
Maximum working pressure: PN16  
Working temperature: 0-80°C  
Powder epoxy coating 250 µm thickness

Color RAL5015  
Bonnet gasket in NBR  
Fully vulcanized ball in EPDM  
Flange standard: EN1092-2

DN	H	A	D	D1	D2	Weight	BLUCAST ref. no.
40	208	250	150	110	84	10	NVD040
50	208	250	165	125	99	11.2	NVD050
65	208	250	185	145	118	12	NVD065
80	250	325	200	160	132	21	NVD080
100	250	325	220	180	154	23.5	NVD100
125	344	440	250	210	184	28	NVD125
150	344	440	285	240	210	48.5	NVD150
200	468	612	310	295	265	55	NVD200

No.	Item	Material
1	Body	EN GJS-500-7
2	Ball	ABS/SS304+EPDM
3	Ball	ABS/SS304+EPDM
4	Gasket	NBR
5	Cover	EN GJS-500-7
6	Bolts	Stainless steel
7	Washer	Stainless steel
8	Gasket	NBR
9	Cover	EN GJS-500-7
10	Valve	Stainless steel

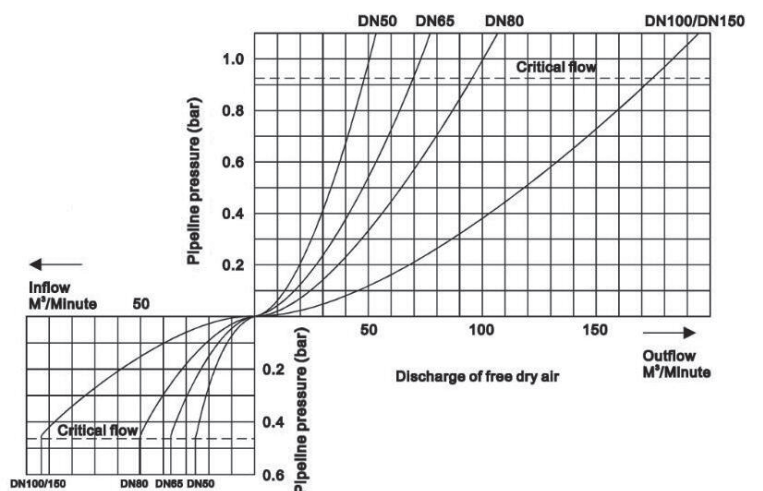
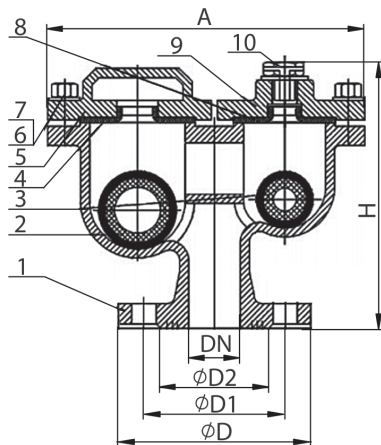

All illustrations, technical data, dimensions (in mm) and weights (all weights specified in kg) are non-binding and are subject to change

