

# DUCKFOOT BEND 90° series N



## TECHNICAL CHARACTERISTICS

Flange end connections according to EN1092-2: PN10/PN16  
 Designed according to EN545  
 Maximum working pressure: PN16 / 16 bar  
 Working temperature: 0°C - +70°C  
 Color RAL5015  
 Powder epoxy coating 250 µm thickness  
 Body from ductile iron EN-GJS-500-7  
 WRAS approved epoxy coating,  
 ACS approved epoxy coating under request

# STUDDED REDUCER FLANGE series XR



## TECHNICAL CHARACTERISTICS

Flange end connections according to EN1092-2  
 Drilling of flanges: PN10/16, starting from DN200 - PN10  
 Maximum working pressure: PN16 / 16 bar  
 Working temperature: 0°C - +70°C  
 Color RAL5015  
 Powder epoxy coating 250 µm thickness  
 Body from ductile iron EN-GJS-500-7  
 WRAS approved epoxy coating  
 Bolts, nuts and washers - hot dip galvanized 8.8 carbon steel



DUCTILE IRON FITTINGS

DN	Flange drilling	L	C	d	e	Weight	BLUCAST ref. no.
80	PN10/16	165	110	180	7	12.2	N080
100	PN10/16	180	125	200	7.2	15	N100
150	PN10/16	220	160	250	7.8	30.5	N150
200	PN10	260	190	300	8.4	47.5	N200
250	PN10	350	225	350	9	76.8	N250
300	PN10	400	255	400	9.6	109	N300
400	PN10	500	320	500	10.8	185	N400
500	PN10	600	385	600	12	292	N500
600	PN10	700	450	700	13.2	446	N600

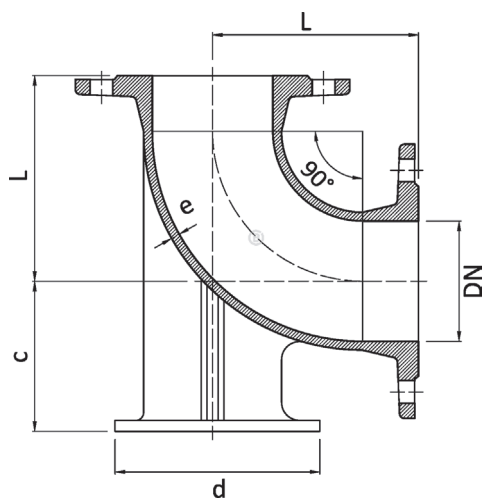

DN1	DN2	Flange drilling	L	Screws	Weight	BLUCAST ref. no.
65	50	PN10/16	45	D	5.6	XR065050
80	50	PN10/16	30	D	5.7	XR080050
80	65	PN10/16	30	D	4.9	XR080065
100	50	PN10/16	30	D	5.4	XR100050
100	65	PN10/16	30	D	5.8	XR100065
100	80	PN10/16	45	D	8.7	XR100080
125	80	PN10/16	31	D	7.5	XR125080
125	100	PN10/16	42	D	8.9	XR125100
150	50	PN10/16	33	S	11	XR150050
150	65	PN10/16	30	S	9.1	XR150065
150	80	PN10/16	30	S	8.8	XR150080
150	100	PN10/16	30	D	11.1	XR150100
150	125	PN10/16	45	D	11.8	XR150125
200	65	PN10	33	S	13.5	XR200065
200	80	PN10	33	S	13.3	XR200080
200	100	PN10	33	S	13.2	XR200100
200	150	PN10	38	S	15	XR200150
250	100	PN10	31	D	21.9	XR250100
250	150	PN10	40	S	26.8	XR250150
250	200	PN10	50	D	22.7	XR250200
300	80	PN10	31	D	26.5	XR300080
300	100	PN10	40	D	26	XR300100
300	150	PN10	31	D	25.3	XR300150
300	200	PN10	32	S	24.1	XR300200
300	250	PN10	33	D	31.2	XR300250
400	100	PN10	38	S	53.8	XR400100
400	150	PN10	38	S	50.2	XR400150
400	200	PN10	38	S	46.2	XR400200
400	250	PN10	38	S	40.3	XR400250
400	300	PN10	39	S	39.8	XR400300
500	100	PN10	47	S	116	XR500100
500	200	PN10	47	S	91	XR500200
500	300	PN10	47	S	84.4	XR500300
500	400	PN10	47	S	100	XR500400

Screwed: S- single set, D- double set

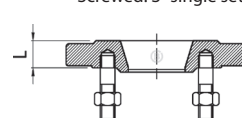
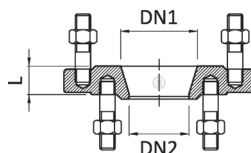

All illustrations, technical data, dimensions (in mm) and weights (all weights specified in kg) are non-binding and are subject to change