

MAXIGRIP UNIVERSAL COUPLING series MGRIP



APPLICATION

Restrained universal coupling provides reliable connection to various types of pipes where tension resistance is required

DESIGN FEATURES

Tensile resistant
Large tolerance
Suitable for ductile iron, steel, PE, PVC, AC pipes
Independent clamping on both sides
Angular deflection up to 4°
Corrosion resistant construction

TECHNICAL CHARACTERISTICS

Mechanical locking by metal inserts to avoid pipe axial movement
Maximum working pressure: PN16 / 16 bar
Working temperature: -10°C - +70°C
Gasket - EPDM (NBR option available)
Bolts, nuts and washers - carbon steel 8.8 hot dip galvanized (other options available)
Galvanised carbon steel tension locks acc. to EN10025
Epoxy powder coating acc. to DIN30677 - minimum 250 µm thickness
Color RAL5015
Tested acc. to EN14525



FLANGE ADAPTORS AND COUPLINGS

DN	D	DE	L	Weight	BLUCAST ref. no.
50	187	46-70	240	7.20	MGRIP050
65	212	70-95	240	8.60	MGRIP065
80	240	88-123	250	10	MGRIP080
100	260	108-143	250	13	MGRIP100
125	285	133-168	260	16	MGRIP125
150	311	159-194	260	17	MGRIP150
200	370	200-235	295	22	MGRIP200
250	420	250-285	305	33	MGRIP250
300	485	315-350	315	41	MGRIP300

No.	Item	Material
1	Bracket	EN GJS-450-12
2	Plastic tension ring	Plastic
3	Gasket	EPDM
4	Body	EN GJS-450-12
5	Grippers	Carbon steel, zinc coated
6	Bolts, nuts, washers	Carbon steel 8.8

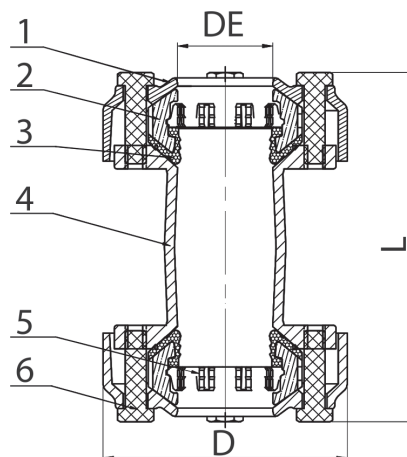

All illustrations, technical data, dimensions (in mm) and weights (all weights specified in kg) are non-binding and are subject to change

