

UNIMAX UNIVERSAL ADAPTOR series AUN



APPLICATION

Universal flange adaptor is used for connecting various pipe materials with flanged fittings

DESIGN FEATURES

Large tolerance
Universal drilling for compatibility with both PN10 and PN16
The bolt ends are protected with plastic caps

TECHNICAL CHARACTERISTICS

Flange end connections according to EN1092-2: PN10/PN16
Maximum working pressure: PN16 / 16 bar
Working temperature: 0°C - +70°C
Color RAL5015
Powder epoxy coating 250 µm thickness
Bolts, nuts and washers - carbon steel 8.8 hot dip galvanized
Maximum angular deflection - 4°

UNIMAX UNIVERSAL COUPLING series MUN



APPLICATION

Universal couplings are used for connecting various pipes

DESIGN FEATURES

Large tolerance
The bolt ends are protected with plastic caps

TECHNICAL CHARACTERISTICS

Maximum working pressure: PN16 / 16 bar
Working temperature: 0°C - +70°C
Color RAL5015
Powder epoxy coating 250 µm thickness
Bolts, nuts and washers - carbon steel 8.8 hot dip galvanized
Maximum angular deflection at each end - 4°



FLANGE ADAPTORS AND COUPLINGS

DN	DE	D	H	Bolts	Bolt qty.	KG	BLUCAST ref. no.
50	57-74	164	75	M12x120	4	3.4	AUN050
65	63-85	182	75	M12x120	4	3.6	AUN065
80	85-107	192	75	M12x120	4	4.4	AUN080
100	107-132	224	75	M12x120	4	5.2	AUN100
125	132-158	246	75	M12x120	4	7.3	AUN125
150	158-184	283	75	M12x120	4	7.4	AUN150
200	200-225	333	75	M12x140	4	10.2	AUN200225
200	218-244	333	75	M12x140	4	10.2	AUN200
225	243-269	375	85	M12x140	6	11	AUN225
250	266-295	394	85	M12x140	6	13.3	AUN250
300	315-349	440	85	M12x140	6	17.6	AUN300
350	351-378	481	111	M14x180	8	29	AUN350
400	400-420	526	111	M14x180	8	31.2	AUN400420
400	417-437	536	111	M14x180	8	32.5	AUN400
500	500-532	715	113	M16x180	10	51	AUN500532
500	526-546	618	113	M14x180	10	47	AUN500
600	630-650	734	115	M14x180	10	63	AUN600

DN	DE	D	H	Bolts	Bolt qty.	KG	BLUCAST ref. no.
50	57-74	164	100	M12x180	2	2.6	MUN050
65	63-85	182	100	M12x180	2	2.8	MUN065
80	85-107	192	100	M12x180	4	3.7	MUN080
100	107-132	224	100	M12x180	4	4.6	MUN100
125	132-158	246	110	M12x190	4	5.5	MUN125
150	158-184	283	110	M12x190	4	6.9	MUN150
175	192-210	304	110	M12x190	4	9.2	MUN175
200	200-225	333	130	M12x210	4	9.7	MUN200225
200	218-244	333	130	M12x210	4	9.7	MUN200
225	243-269	375	130	M12x210	4	11	MUN225
250	266-295	394	130	M12x220	6	12.5	MUN250
300	315-349	440	130	M12x220	6	15.3	MUN300
350	351-378	481	130	M14x250	8	27	MUN350
400	417-437	536	130	M14x250	8	28	MUN400
500	526-546	618	130	M14x250	10	38.5	MUN500
600	630-650	734	130	M14x250	10	59	MUN600

No.	Item	Material
1	Bracket	Ductile iron EN-GJS-500-7
2	Body	Ductile iron EN-GJS-500-7
3	Bolt	8.8 carbon steel hot dip galvanized
4	Sealing gasket	EPDM

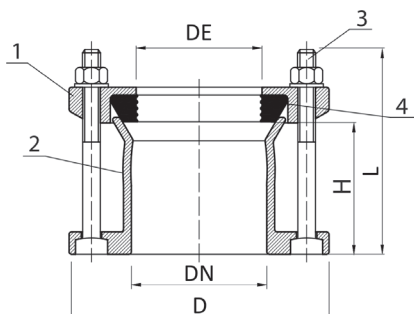

No.	Item	Material
1	Bracket	Steel
2	Body	Ductile iron EN-GJS-500-7
3	Bolt	8.8 carbon steel hot dip galvanized
4	Sealing gasket	EPDM

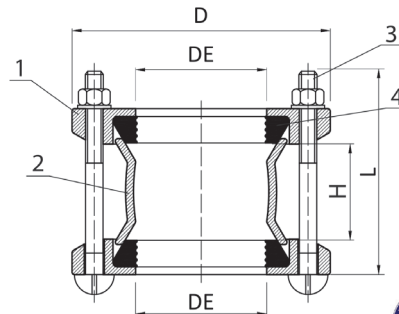

All illustrations, technical data, dimensions (in mm) and weights (all weights specified in kg) are non-binding and are subject to change

