

# SWING CHECK VALVE series ASV



GATE VALVES



## APPLICATION

Swing check valve used for stopping of backflow of drinking water and neutral liquids up to 80°C

## DESIGN FEATURES

Simple and compact design  
Can be installed in vertical and horizontal positions  
Maintenance free

## TECHNICAL CHARACTERISTICS

Face to face dimensions according to EN558 series 48 / DIN3202 (F6)  
Flange end connections according to EN1092: PN10&PN16  
Maximum working pressure: PN16  
Working temperature: 0-80°C  
Color RAL5015  
Powder epoxy coating 250 µm thickness  
Hydraulic test according to EN12266

DN	Flange drilling	L	D	D1	D2	b	n-Ød	KG	BLUCAST ref. no.
50	PN10/16	200	165	125	100	19	4-Ø19	8.5	ASV050
65	PN10/16	240	185	145	120	19	4-Ø19	10.2	ASV065
80	PN10/16	260	200	160	135	19	8-Ø19	14.4	ASV080
100	PN10/16	300	220	180	156	19	8-Ø19	19.1	ASV100
125	PN10/16	350	250	210	186	19	8-Ø19	26.3	ASV125
150	PN10/16	400	285	240	212	19	8-Ø23	33.5	ASV150
200	PN10	500	340	295	268	20	8-Ø23	68.5	ASV200
250	PN10	600	405	350	318	22	12-Ø23	125	ASV250
300	PN10	700	460	400	370	24.5	12-Ø23	160	ASV300

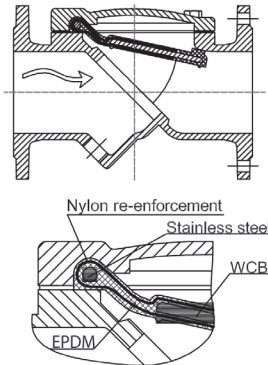
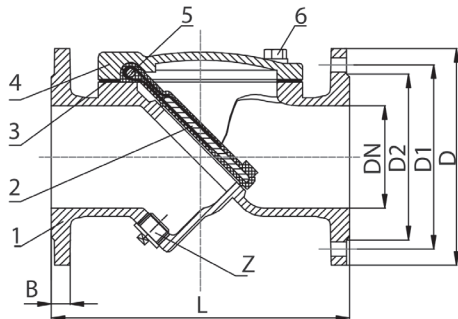

No.	Item	Material
1	Body	EN GJS-500-7
2	Disc	WCB+EPDM
3	Gasket	EPDM
4	Bonnet	EN GJS-500-7
5	Pin	AISI304
6	Bolts	AISI304
7	Plug	AISI304

All illustrations, technical data, dimensions (in mm) and weights (all weights specified in kg) are non-binding and are subject to change