

BALL CHECK VALVE series ARV



APPLICATION

Ball check valves for drinking water and neutral liquids up to 70°C
NBR version for sewage

DESIGN FEATURES

Self cleaning construction
Full bore
Easy disassembly of the top cap to remove the ball
Simple and compact design
Can be installed in vertical and horizontal positions

TECHNICAL CHARACTERISTICS

Maximum working pressure: PN10 / PN16
Working temperature: 0°C - +70°C
Fully vulcanized ball in EPDM (NBR option available)
Color RAL5015
Powder epoxy coating 250 µm thickness
Bonnet gasket in EPDM

Flanged version:

Design in accordance to EN12050
Face to face dimensions according to:
EN558 series 48 / DIN 3202 (F6)
Flange end connections according to
EN1092-2: PN10&PN16

Threaded version:

Thread connections according to EN 10226-1



GATE VALVES

DN	Flange drilling	L	D	D1	D2	b	n-Ød	KG	BLUCAST ref. no.
32	1 1/4" thread	140	-	-	-	18	-	2,5	ARVVV032
40	1 1/2" thread	145	-	-	-	18	-	2,6	ARVVV040
50	2" thread	170	-	-	-	20	-	3,8	ARVVV050
50	PN10/16	200	165	125	102	19	4-Ø19	8,5	ARV050
65	PN10/16	240	185	145	122	19	4-Ø19	9,5	ARV065
80	PN10/16	280	200	160	138	19	8-Ø19	12	ARV080
100	PN10/16	300	220	180	158	19	8-Ø19	16	ARV100
125	PN10/16	350	250	210	188	19	8-Ø19	22	ARV125
150	PN10/16	400	285	240	212	19	8-Ø23	31	ARV150
200	PN10	500	340	295	268	20	8-Ø23	68	ARV200
250	PN10	600	405	350	319	22	12-Ø23	100	ARV250
300	PN10	700	460	400	370	24,5	12-Ø23	132	ARV300
400	PN10	900	580	515	480	28	16-Ø28	275	ARV400
200	PN16	500	340	295	266	20	12-Ø23	68	ARVP200
250	PN16	600	400	355	319	22	12-Ø28	100	ARVP250
300	PN16	700	455	410	370	24,5	12-Ø28	132	ARVP300

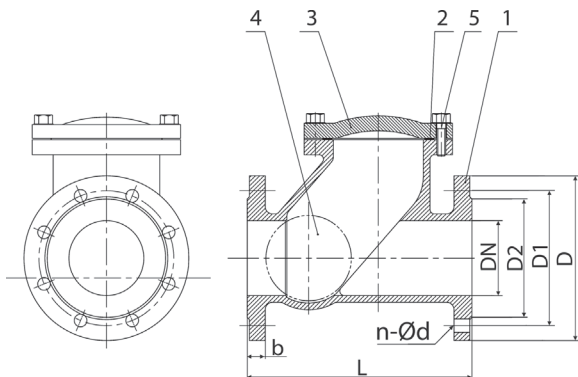

No.	Item	Material
1	Body	EN-GJS-400-15
2	Gasket	EPDM
3	Cover	EN-GJS-400-15
4	Ball	Q235 Steel + EPDM
5	Bolt	Zinc plated 4.8 steel or Stainless steel AISI304

All illustrations, technical data, dimensions (in mm) and weights (all weights specified in kg) are non-binding and are subject to change

